



# Low Energy Consumption AQMS Monitors

World's Premiere Solar Air Quality Monitoring Station



U.S. EPA  
APPROVAL



TÜV Rheinland®  
QAL1 CERTIFICATION



24V



Application note



## WORLD'S PREMIERE 100% AUTONOMOUS STATION

ENVEA, worldwide leader in ambient monitoring systems and very invested in ecodesign, introduces the 1<sup>st</sup> Solar AQMS, representing a major breakthrough for the air quality monitoring.

The standalone station encloses ENVEA's e-Series analyzers, QAL 1 certified and US-EPA approved, offering the best metrological performances for the continuous monitoring of gases CO, O<sub>3</sub>, NO<sub>x</sub>, SO<sub>2</sub> and fines particulates PM10 or PM2.5.

This sturdy series of criteria monitors, offer very low energy consumption, are insensitive to temperature variations and are 24V power supplied. Thus, the air quality monitoring station is able to withstand temperatures up to 45-50 °C without air conditioning and without connection to the power grid.

The station being equipped with data acquisition & handling systems, the measured parameters are automatically and wireless transmitted to a central server for global supervision and management.



Thanks to the ENVEA e-Series unique features, for the first time in the world, a complete standalone monitoring station, supplied only by green energy and measuring 24 hours a day, can be installed in isolated site.

This innovation will revolutionize the air quality measurement across the developing world struggling with the reliability of their energy supply, as well as the forward-thinking 'smart cities' looking to re-define their energy mix and supporting renewables on the grid.

# CASE STUDY

e-Series low consumption monitors installed in a turnkey AQMS station solar powered, air conditioning free, architected and installed in France

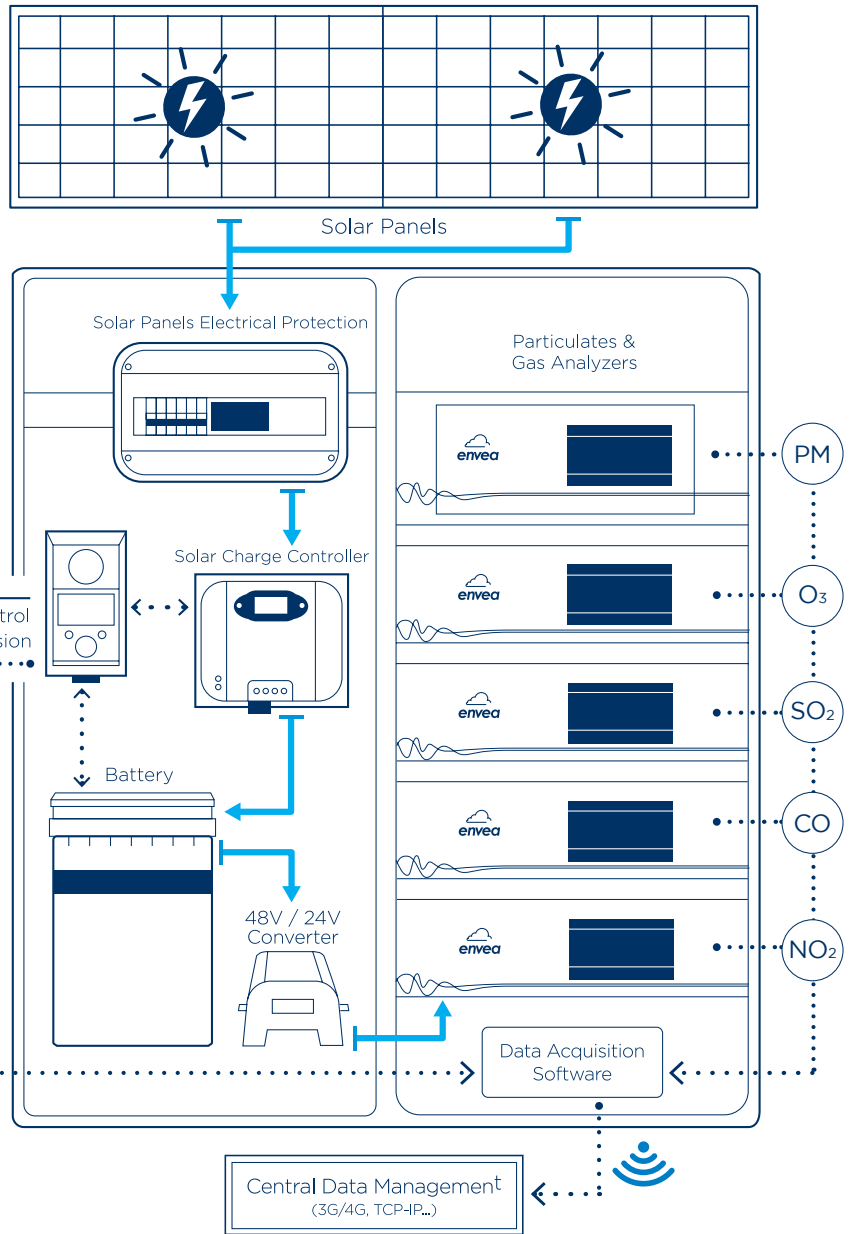
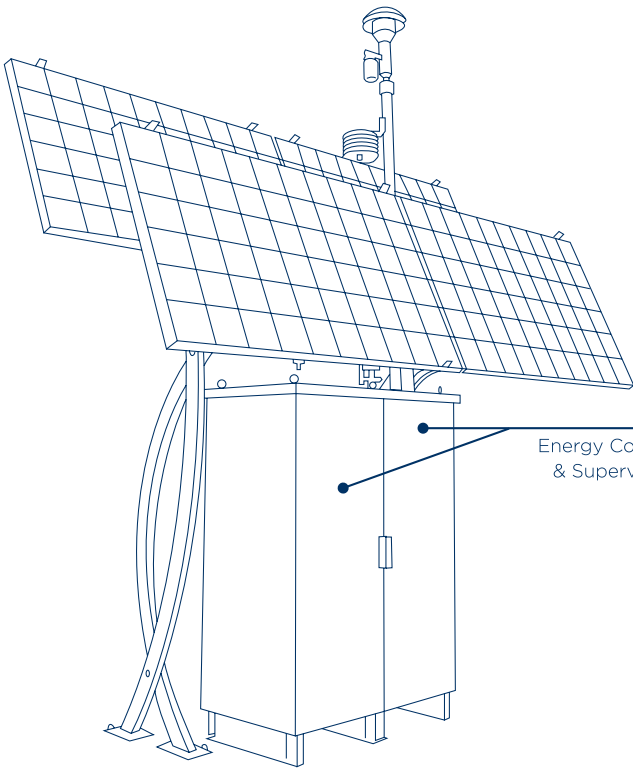

The solar panel converts sunlight into DC electricity to feed the battery via a solar regulator which ensures the battery is charged properly and not damaged.

An intelligent Energy Management System (EMS) controls the charge and discharge process and automatically redirects the excess solar energy to the battery bank for storage and use during the night and to compensate, some days, the lack of sunlight.

The battery insures the uninterrupted 24V supply to the analyzers for continuous air quality measurements.

The station, number and model of e-Series analyzers, the energy supply and equipment (solar panels, batteries, windmill, fuel cell...) DAHS, software, etc shall be customized to fit your specific needs, with possibility to mix energy sources.

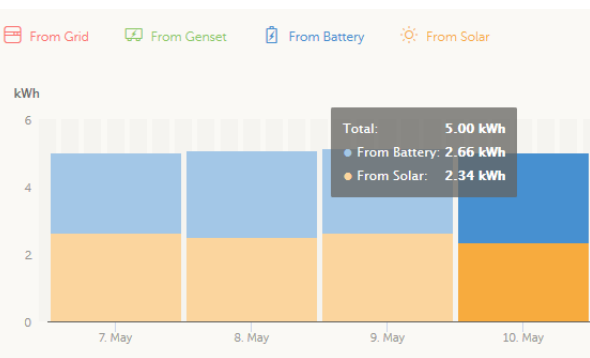

Solar AQMS daily consumption distribution



During sunny days, the solar energy is used directly by the analyzers. The excess is stored in the battery bank.

Over the night and cloudy days, the station works on battery.

Local integration, through our world-class distribution network, allow for tailored design according to site requirements, local regulations and monitoring needs.

By providing locally all the necessary supplies (solar panels, batteries, cabinet, etc.) you will benefit from local knowledge and support, increased flexibility, reduced supply chain costs and compliance with regulations.

Furthermore, localizing your supply chain represents a tremendous opportunity to help the environment. When you reduce shipping and storage, you also reduce emissions and energy usage.



**SERIES**

## UNIQUE STEP TOWARDS A SUSTAINABLE ECO-DESIGN

A forerunner in its domain, ENVEA has adopted a systematic process to integrate sustainability in its research and development, embedding eco-design across its businesses.

The e-Series of analyzers has been fully eco-designed and offer the best metrological performances on the market for the continuous monitoring of CO, O<sub>3</sub>, NO<sub>x</sub>, SO<sub>2</sub>, PM<sub>10</sub> & PM<sub>2.5</sub>.



U.S. EPA  
**APPROVED**



TÜV Rheinland  
**QAL1 CERTIFIED**

### e-Series MAIN ADVANTAGES:

- > Environmental friendly:
  - . Sustainable eco-design
  - . Low carbon footprint
  - . Over 95% of the analyzer can be recycled
  - . Ultra low power consumption
- > Long lifespan, excellent accuracy
- > Economic, easy and reduced maintenance
- > Common electronic boards (optimized spare parts stock)
- > Service Assistant inside
- > Smart, connected instruments
- > Proactive and user-friendly remote communication
- > 24V powered analyzers



# e-SERIES ANALYZERS

Reducing air pollution is a major challenge worldwide. ENVEA's pioneering technologies help private, public and local authorities to meet their air quality challenges and objectives.

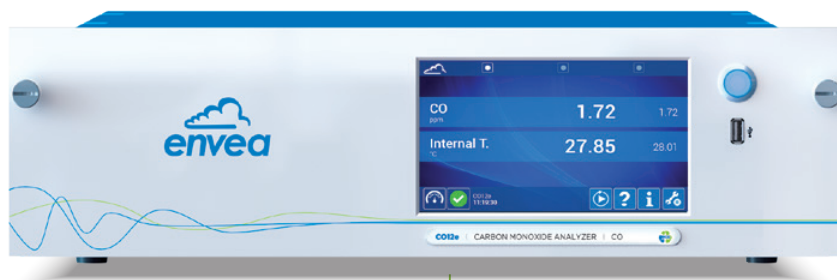

+



## Smart, connected instruments

The e-Series are integrating an embedded web server for the easiest remote access to full operation of the analyzer from any PC, tablet or Smart-phone.

+



## Service Assistant Inside

Engineered with breakthrough technologies, the ENVEA's e-Series integrates a high level of self-operation and self diagnosis. They even guide the service operations.

+



## Operational Cost Reduction

Analyzers share similar design & electronic boards for optimized stock of spare parts. Their power consumption is 80% less compared to other analyzer's on the market.

# MEASURED COMPOUNDS



## Continuous Automated Suspended Particulate Monitor - MP101M

The MP101M uses the standard ISO 10473 beta gauge measurement method for the continuous monitoring of PM10 (EN 12341 & US-EPA) and PM2.5 (EN 14907, US-EPA & J-MOE).



## Ozone analyzer - O342e

It uses the UV Direct Absorption (UV-DA) technology combined with a patented optical technology to ensure the most reliable O<sub>3</sub> monitoring on the market, in compliance with EN 14625.



## Sulfur Dioxide analyzer - AF22e

The AF22e is based on the UV Fluorescence Technique (EN 14212) to continuously measure sulfur dioxide (SO<sub>2</sub>) concentrations.



## Carbon Monoxide analyzer - CO12e

The CO12e analyzer quantifies the carbon monoxide (CO) concentrations. Its measurement method is based on the NDIR (Non Dispersive Infrared) Absorption Principle (EN 14626).



## Nitrogen Oxides analyzer - AC32e

The AC32e uses the CLD Chemiluminescence Detection, the reference method according the EN 14211 to measure nitrogen oxides (NO-NO<sub>x</sub> and NO<sub>2</sub>) concentrations.

*The AS32M, using patented Cavity Attenuated Phase Shift (CAPS) technology for direct measurement of NO<sub>2</sub>, can be an alternative to the AC32e, with lower energy consumption.*

REFERENCE MONITORS	MP101M	O342e	AF22e	CO12e	AC32e	AS32M
Measured compounds	PM 10 & PM 2.5	O <sub>3</sub>	SO <sub>2</sub>	CO-CO <sub>2</sub>	NO-NO <sub>2</sub>	NO <sub>2</sub>
Measuring range (ppm)	0-100000 µg/m <sup>3</sup>	0-0.5 / 0-10	0-1 / 0-10	0-50 / 0-300	0-1 / 0-10	0-1
Detection Limit (2σ)	0.5 µg/m <sup>3</sup> (/24h)	0.2 ppb	<0.4 ppb	50 ppb	<0.2 ppb	0.1 ppb
19" rack enclosure	6U	3U	3U	3U	3U	3U
Weight (kg)	15,2	9,5	9.8	8	10,3	10
Power consumption (W.h)	75 - 90	23	41	22	75	35





## DATA ACQUISITION & MANAGEMENT SYSTEM

The AQMS Solar Station includes the e-SAM™ data acquisition module (logger & router) handling all the measured parameters: analyzers, meteorological and temperature sensors, energy supervision... It ensures remote, bi-directional access and control of analyzers and the EMS via a WEB based interface.

Furthermore, these data can be automatically and wireless transmitted to a central server, equipped with the XR® software suite, able to handle networkly thousands of AQMS stations in a town, city or region.

Fully compliant with international guidelines & standards, the XR® software suite by ENVEA provides breakthrough features:

- > Acquisition, processing and display of any type of environmental data: gas & dust analyzers, meteorological sensors...
- > Traceability and high availability of the raw and validated data
- > Advanced statistics, automatic data validation and reports
- > Advanced control of the measurement chain
- > Input and import of analysis results

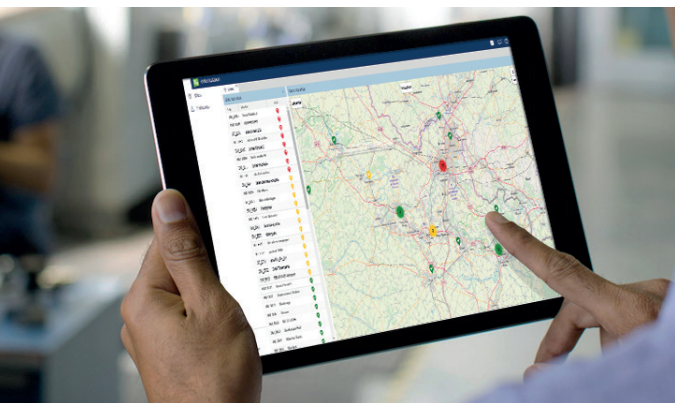

### COMPLIANCE WITH:

- European Directive 2008/50/CE
- AFNOR NF X 06-044
- ISO 7168-1: 1999

# A STRONG GLOBAL PRESENCE

Faithful to the principles on which it was founded – innovation & quality, social responsibility & shared value – the ENVEA group is committed to providing you with solutions and assistance at the highest standards in order to comply with applicable regulations; as well as the optimization of industrial processes for an improved efficiency, significant savings of raw materials & energy, the reduction of environmental impacts...

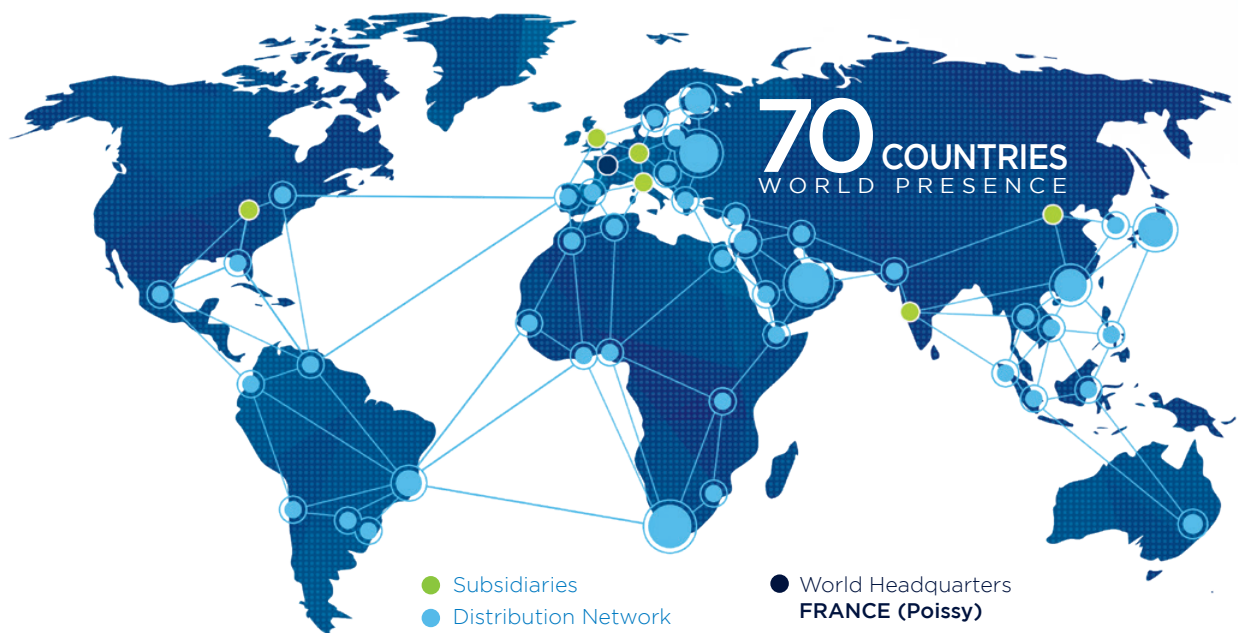

Our references guarantee a perfect understanding of your needs and ability to manage a vast range of applications:

More than 37,000 of ENVEA air quality monitors are measuring the pollution of cities worldwide: Paris, Rio de Janeiro, Istanbul, Seoul, Hanoi, Abu Dhabi...

Over 28,500 emission sources & processes monitored worldwide across a broad range of industries such as: cement plants, metal factories, waste to energy plants...

Process - Emissions - Ambient  
monitoring solutions



**ENVEA (Headquarters)**  
111 Bd Robespierre - CS 80004  
78300 Poissy / Cedex 4 - FRANCE  
☎ +33(0) 1 39 22 38 00  
✉ info@envea.global



Visit us on:  
[www.envea.global](http://www.envea.global)

