



REFLEX RA SERIES Handbook

80 GHz Radar (FMCW) Level Transmitter for liquids with hygienic requirements

All rights reserved. It is prohibited to reproduce this documentation, or any part thereof, without the prior written authorisation of HYCONTROL.

Subject to change without notice.

Copyright 2019 by HYCONTROL

1	Safety instructions	6
<hr/>		
1.1	Software history	6
1.2	Intended use	7
1.3	Certification	7
1.4	Radio approvals	8
1.4.1	European Union (EU).....	8
1.4.2	U.S.A.....	10
1.4.3	Canada.....	12
1.5	Safety instructions from the manufacturer	14
1.5.1	Copyright and data protection	14
1.5.2	Disclaimer	14
1.5.3	Product liability and warranty	15
1.5.4	Information concerning the documentation.....	15
1.5.5	Warnings and symbols used.....	16
1.6	Safety instructions for the operator.....	16
2	Device description	17
<hr/>		
2.1	Scope of delivery.....	17
2.2	Device description	18
2.3	Visual Check	19
2.4	Nameplates	20
2.4.1	Nameplate (examples).....	20
3	Installation	21
<hr/>		
3.1	General notes on installation	21
3.2	Storage	21
3.3	Transport	22
3.4	Pre-installation requirements	22
3.5	Pressure and temperature ranges	23
3.6	Recommended mounting position	24
3.6.1	General notes.....	24
3.6.2	Tanks with dish-shaped and conical bottoms.....	26
3.7	Mounting restrictions	27
3.7.1	General notes.....	27
3.7.2	Process connections.....	29
3.8	How to turn or remove the display module (option)	34
3.9	Weather protection.....	35
3.9.1	How to attach the weather protection to the device.....	35
3.9.2	How to open the weather protection	37
4	Electrical connections	38
<hr/>		
4.1	Safety instructions.....	38
4.2	General notes	38
4.3	Electrical installation: output options with cable gland.....	39
4.4	Electrical installation: output options with an M12 male connector.....	43

4.5	Electrical connection for current output	43
4.5.1	Non-Ex devices	43
4.5.2	Devices for hazardous locations	44
4.6	Ingress protection	44
4.7	Networks	45
4.7.1	General information	45
4.7.2	Point-to-point connection	45
4.7.3	Multi-drop networks	46
5	Start-up	47
<hr/>		
5.1	Start-up checklist	47
5.2	How to start the device	47
5.3	Operating concept	47
5.4	Digital display screen	48
5.4.1	Display screen layout	48
5.4.2	Keypad buttons	49
5.5	Remote communication with PACTware™	51
5.6	Remote communication with the AMST™ Device Manager	52
6	Operation	53
<hr/>		
6.1	User modes	53
6.2	Normal mode	53
6.3	Program mode	57
6.3.1	General notes	57
6.3.2	Protection of the device settings (access levels)	57
6.3.3	How to get access to the Quick Setup menu	59
6.3.4	Keypad functions	60
6.3.5	How to save settings changed in Program mode	63
6.3.6	Menu overview	64
6.3.7	Function description	70
6.4	Further information on device configuration in Program mode	88
6.4.1	Standard setup	88
6.4.2	Empty spectrum recording	92
6.4.3	HART® network configuration	94
6.4.4	Distance measurement	95
6.4.5	Level measurement	97
6.4.6	How to configure the device to measure volume or mass	99
6.4.7	How to measure correctly in tanks with curved or conical bottoms	101
6.4.8	How to make a filter to remove radar signal interference	102
6.5	Status messages and diagnostic data	103
7	Service	110
<hr/>		
7.1	Periodic maintenance	110
7.1.1	General notes	110
7.1.2	Maintenance of the O-rings for the housing covers	110
7.1.3	How to clean the top surface of the device	111
7.2	Service warranty	111
7.3	Spare parts availability	112

7.4 Availability of services	112
7.5 Returning the device to the manufacturer	113
7.5.1 General information	113
7.5.2 Form (for copying) to accompany a returned device	114
7.6 Disposal	114
8 Technical data	115
8.1 Measuring principle	115
8.2 Technical data	117
8.3 Measuring accuracy	122
8.4 Minimum power supply voltage	124
8.5 Dimensions and weights	126
9 Description of HART interface	130
9.1 General description	130
9.2 Software history	131
9.3 Connection variants	131
9.3.1 Point-to-Point connection – analogue / digital mode	131
9.3.2 Multi-Drop connection (2-wire connection)	132
9.4 HART® device variables	132
9.5 Field Communicator 475 (FC 475)	132
9.5.1 Installation	132
9.5.2 Operation	133
9.6 Asset Management Solutions (AMS®)	133
9.6.1 Installation	133
9.6.2 Operation	133
9.6.3 Parameter for the basic configuration	133
9.7 Field Device Tool / Device Type Manager (FDT / DTM)	134
9.7.1 Installation	134
9.7.2 Operation	134
9.8 Process Device Manager (PDM)	134
9.8.1 Installation	134
9.8.2 Operation	134
9.9 HART® menu tree for AMS	135
9.9.1 Overview AMS menu tree (positions in menu tree)	135
9.9.2 AMS menu tree (details for settings)	136
9.10 HART® menu tree for PDM	138
9.10.1 Overview PDM menu tree (positions in menu tree)	139
9.10.2 PDM menu tree (details for settings)	140
10 Appendix	143
10.1 Order code	143
10.2 Spare parts	146
10.3 Accessories	148
10.4 Glossary	149

1.1 Software history

"Firmware revision" agrees with NAMUR NE 53. It is a series of numbers used to record the revision status of embedded software (firmware) in electronic equipment assemblies. It gives data on the type of changes made and the effect that changes have on compatibility.

Data about software revisions is shown in menu 1.1.0 IDENT. For more data, refer to *Function description* on page 70. If it is not possible to refer to the device menu, record the serial number of the device (given on the device nameplate) and speak to the supplier.

Changes and effect on compatibility

1	Downwards compatible changes and fault repair with no effect on operation (e.g. spelling mistakes on display)	
2- _	Downwards compatible hardware and/or software change of interfaces:	
	H	HART®
	P	Profibus
	F	FOUNDATION fieldbus
3- _	Downwards compatible hardware and/or software change of inputs and outputs:	
	CO	Current output
	FO, PO	Frequency output / pulse output
	SO	Status output
	LS	Limit switch
	CI	Current input
	D	Display

Release date	Printed circuit assembly	Firmware revision	Electronic revision	Hardware revision	Changes and compatibility	Documentation
2019-03-27	HMI (LCD display option)	BL1.31.06	ER2.0.0_	4002905801b ①	—	RA MANUAL R01
	Main and Support			4002815701f		
	Sensor			4004742601b		

① If the device does not have the display module option, the module reference number is 4002905802a

1.2 Intended use

**CAUTION!**

Responsibility for the use of the measuring devices with regard to suitability, intended use and corrosion resistance of the used materials against the measured fluid lies solely with the operator.

**INFORMATION!**

The manufacturer is not liable for any damage resulting from improper use or use for other than the intended purpose.

This radar level transmitter measures distance, level, mass, volume and reflectivity of liquids, pastes and slurries.

It can be installed on tanks for hygienic applications.

1.3 Certification

**DANGER!**

For devices used in hazardous areas, additional safety notes apply; please refer to the Ex documentation.

CE marking**The device meets the essential requirements of the EU Directives:**

- Electromagnetic Compatibility (EMC) directive
- The safety part of the Low-Voltage directive
- For devices used in hazardous locations: ATEX directive

The manufacturer certifies successful testing of the product by applying the CE marking. For more data about the EU Directives and European Standards related to this device, refer to the EU Declaration of Conformity. You can download this document free of charge from the website.

All devices are based on the CE marking and meet the requirements of NAMUR Recommendations NE 21, NE 43, NE 53 and NE 107.

1.4 Radio approvals

1.4.1 European Union (EU)



INFORMATION!

LPR (Level Probing Radar) devices measure level in the open air or in a closed space (a metallic tank etc.). **TLPR (Tank Level Probing Radar)** devices measure level in a closed space only. You can use LPR devices for TLPR applications. The LPR and TLPR devices meet the requirements of the RED (Radio Equipment Directive) for use in the member countries of the EU.

For more data about the order code, refer to *Order code* on page 143.

This level transmitter is approved to be used outside metallic tanks. If you use the device in the open air, read the device nameplate to make sure that the device can be used for your application. Refer also to the table that follows:

Antenna type	Order code	Permitted for:
PEEK / DN25 (1") Lens	RAxxxxxxxxxx2xx...	TLPR
PEEK / DN40 (1½") Lens	RAxxxxxxxxxx3xx...	LPR + TLPR

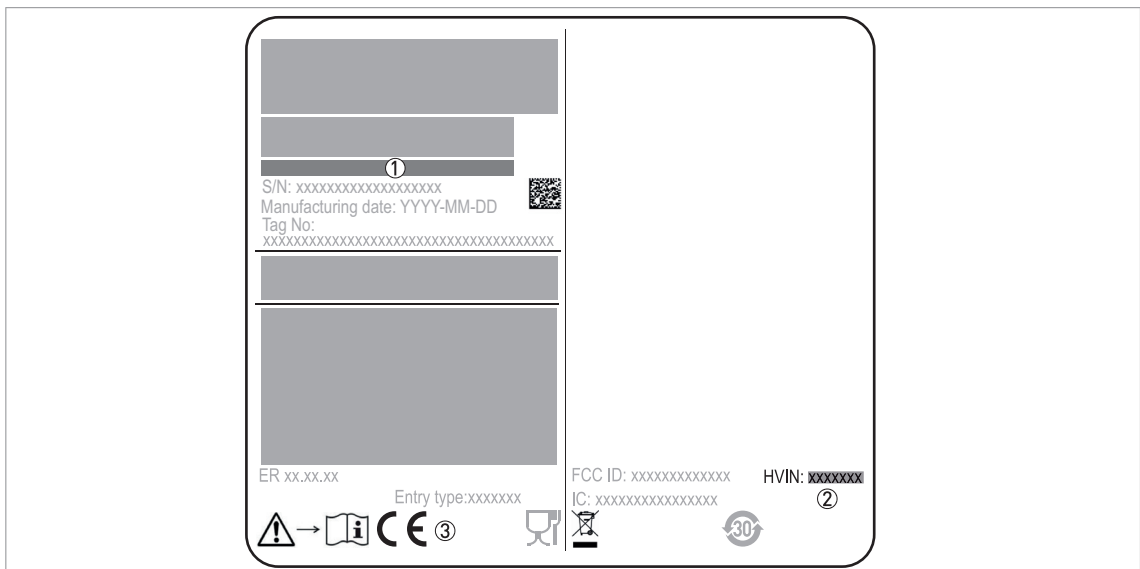

Figure 1-1: European Union: radio approval information on the nameplate

- ① Type code (defined in order). For more data, refer to *Order code* on page 143.
- ② HVIN (Hardware Version Identification Number). This number gives the radar signal frequency (80GHZ = 80 GHz), the location of the device (T=TLPR or L=LPR) and the type of signal converter (compact [C])
 TLPR device: HVIN: 80GHZ-T-C
 LPR device: HVIN: 80GHZ-L-C
- ③ CE sign

TLPR (Tank Level Probing Radar) devices only

Use approved personnel to install the device. The device and the tank agree with the RED (Radio Equipment Directive) if you obey the instructions that follow:

- TLPR (Tank Level Probing Radar) are required to be installed at a permanent fixed position at a closed (not open) metallic tank or reinforced concrete tank, or similar enclosure structure made of comparable attenuating material;
- flanges and attachments of the TLPR equipment shall provide the necessary microwave sealing by design;
- sight glasses shall be coated with a microwave-proof coating when necessary (i.e. electrically conductive coating);
- manholes or connection flanges at the tank shall be closed to ensure a low-level leakage of the signal into the air outside the tank;
- whenever possible, mounting of the TLPR equipment shall be on top of the tank structure with the orientation of the antenna to point in a downward direction;
- installation and maintenance of the TLPR equipment shall be performed by professionally trained individuals only.

For data about how to install EMI/RFI shielding gaskets, refer to the instructions supplied with this accessory.

LPR (Level Probing Radar) devices only

Use approved personnel to install the device. If the device is operated in the open air (outdoors), it agrees with the RED (Radio Equipment Directive) if you obey these instructions:



- The antenna must always point downwards. The boresight direction of the antenna must be vertical. No other angles are permitted.
- Install the device more than 4 km / 2.485 mi away from radio astronomy sites.
- If the device is 4...40 km / 2.485...24.855 mi away from radio astronomy sites, do not install the device more than 15 m / 49.21 ft above the ground.



CAUTION!

If it is necessary to install the device less than 4 km / 2.485 mi from radio astronomy sites, you must get the approval of the national regulatory authority before installation (e.g. ANFR (France), Bundesnetzagentur (Germany), Ofcom (United Kingdom) etc.).

Radio quiet zones: locations of radio astronomy sites (stations) in Europe and northern Eurasia

Country	Name of the station	Location	
		Latitude, φ	Longitude, λ
Finland	Metsähovi	60°13'04" N	24°23'37" E
France	Plateau de Bure	44°38'01" N	05°54'26" E
Germany	Effelsberg	50°31'32" N	06°53'00" E
Italy	Sardinia	39°29'50" N	09°14'40" E
Spain	Yebes	40°31'27" N	03°05'22" W
	Pico Veleta	37°03'58" N	03°23'34" W
Sweden	Onsala	57°23'45" N	11°55'35" E

1.4.2 U.S.A.



INFORMATION!

LPR (Level Probing Radar) devices measurement level in the open air or in a closed space (a metallic tank etc.). TLPR (Tank Level Probing Radar) devices measure of level in a closed space only.

This level transmitter is approved to be used outside metallic tanks. If you use the device in the open air, read the device nameplate to make sure that the device can be used for your application. Refer also to the table that follows:

Antenna type	Order code	Permitted for:
PEEK / DN25 (1") Lens	RAxxxxxxxxxx2xx...	TLPR
PEEK / DN40 (1½") Lens	RAxxxxxxxxxx3xx...	LPR + TLPR



LEGAL NOTICE!

This device complies with Part 15 of the FCC Rules. Operation is subject to the following two conditions:

- 1. This device may not cause harmful interference, and*
- 2. This device must accept any interference received, including interference which may cause undesired operation.*

Changes or modifications made to this equipment not expressly approved by the manufacturer may void the FCC authorizations to operate this equipment.

This equipment has been tested and found to comply with the limits for a Class B digital device, pursuant to Part 15 of the FCC Rules. These limits are designed to provide reasonable protection against harmful interference in a residential installation. This equipment generates, uses and can radiate radio frequency energy and, if not installed and used in accordance with the instructions, may cause harmful interference to radio communications. However, there is no guarantee that interference will not occur in a particular installation. If this equipment does cause harmful interference to radio or television reception, which can be determined by turning the equipment off and on, the user is encouraged to try to correct the interference by one or more of the following measures:

- Reorient or relocate the receiving antenna.*
- Increase the separation between the equipment and receiver.*
- Connect the equipment into an outlet on a circuit different from that to which the receiver is connected.*
- Consult the dealer or an experienced radio/TV technician for help.*

The Product Marketing Names (PMN) for this series of devices are "REFLEX RA SERIES FMCW RADAR", "REFLEX RD SERIES FMCW RADAR" and "REFLEX RF SERIES FMCW RADAR".

1.4.3 Canada



INFORMATION!

LPR (Level Probing Radar) devices measure level in the open air or in a closed space (a metallic tank etc.). **TLPR (Tank Level Probing Radar)** devices measure level in a closed space only.

This level transmitter is approved to be used outside metallic tanks. If you use the device in the open air, read the device nameplate to make sure that the device can be used for your application. Refer also to the table that follows:

Antenna type	Order code	Permitted for:
PEEK / DN25 (1") Lens	RAxxxxxxxxxx2xx...	TLPR
PEEK / DN40 (1½") Lens	RAxxxxxxxxxx3xx...	LPR + TLPR



LEGAL NOTICE!

This device complies with Industry Canada licence-exempt RSS standard(s).

Operation is subject to the following conditions:

1. *this device may not cause harmful interference, and*
2. *this device must accept any interference received, including interference that may cause undesired operation.*

This device and the handbook complies with the requirements of RSS-Gen. Operation is subject to the conditions that follow:

1. *The installation of the LPR/TLPR device shall be done by trained installers, in strict compliance with the manufacturer's instructions.*
2. *The use of this device is on a "no-interference, no-protection" basis. That is, the user shall accept operations of high-powered radar in the same frequency band which may interfere with or damage this device. However, devices found to interfere with primary licensing operations will be required to be removed at the user's expense.*
3. *The TLPR device shall be installed and operated in a completely enclosed container to prevent RF emissions, which can otherwise interfere with aeronautical navigation.*
4. *LPR devices: Ensure a vertically downward orientation of the transmit antenna and an installation only at fixed locations.*
5. *The installer / user of this device shall ensure that it is at least 10 km from the Dominion Radio Astrophysical Observatory (DRAO) near Penticton, British Columbia. The coordinates of the DRAO are latitude 49° 19' 15" N and longitude 119° 37' 12" W. For devices not meeting this 10 km separation (e.g. those in the Okanagan Valley, British Columbia) the installer / user must coordinate with, and obtain the written concurrence of, the Director of the DRAO before the equipment can be installed or operated. The Director of the DRAO may be contacted at 250-497-2300 (tel.) or 250-497-2355 (fax). Alternatively, the Manager, Regulatory Standards, Industry Canada, may be contacted.*

The Product Marketing Names (PMN) for this series of devices are "REFLEX RA SERIES FMCW RADAR", "REFLEX RD SERIES FMCW RADAR" and "REFLEX RF SERIES FMCW RADAR".

1.5 Safety instructions from the manufacturer

1.5.1 Copyright and data protection

The contents of this document have been created with great care. Nevertheless, we provide no guarantee that the contents are correct, complete or up-to-date.

The contents and works in this document are subject to copyright. Contributions from third parties are identified as such. Reproduction, processing, dissemination and any type of use beyond what is permitted under copyright requires written authorisation from the respective author and/or the manufacturer.

The manufacturer tries always to observe the copyrights of others, and to draw on works created in-house or works in the public domain.

The collection of personal data (such as names, street addresses or e-mail addresses) in the manufacturer's documents is always on a voluntary basis whenever possible. Whenever feasible, it is always possible to make use of the offerings and services without providing any personal data.

We draw your attention to the fact that data transmission over the Internet (e.g. when communicating by e-mail) may involve gaps in security. It is not possible to protect such data completely against access by third parties.

We hereby expressly prohibit the use of the contact data published as part of our duty to publish an imprint for the purpose of sending us any advertising or informational materials that we have not expressly requested.

1.5.2 Disclaimer

The manufacturer will not be liable for any damage of any kind by using its product, including, but not limited to direct, indirect or incidental and consequential damages.

This disclaimer does not apply in case the manufacturer has acted on purpose or with gross negligence. In the event any applicable law does not allow such limitations on implied warranties or the exclusion of limitation of certain damages, you may, if such law applies to you, not be subject to some or all of the above disclaimer, exclusions or limitations.

Any product purchased from the manufacturer is warranted in accordance with the relevant product documentation and our Terms and Conditions of Sale.

The manufacturer reserves the right to alter the content of its documents, including this disclaimer in any way, at any time, for any reason, without prior notification, and will not be liable in any way for possible consequences of such changes.

1.5.3 Product liability and warranty

The operator shall bear responsibility for the suitability of the device for the specific purpose. The manufacturer accepts no liability for the consequences of misuse by the operator. Improper installation or operation of the devices (systems) will cause the warranty to be void. The respective "Standard Terms and Conditions" which form the basis for the sales contract shall also apply.

1.5.4 Information concerning the documentation

To prevent any injury to the user or damage to the device it is essential that you read the information in this document and observe applicable national standards, safety requirements and accident prevention regulations.

If this document is not in your native language and if you have any problems understanding the text, we advise you to contact your local office for assistance. The manufacturer can not accept responsibility for any damage or injury caused by misunderstanding of the information in this document.

This document is provided to help you establish operating conditions, which will permit safe and efficient use of this device. Special considerations and precautions are also described in the document, which appear in the form of icons as shown below.

1.5.5 Warnings and symbols used

Safety warnings are indicated by the following symbols.



DANGER!

This warning refers to the immediate danger when working with electricity.



DANGER!

This warning refers to the immediate danger of burns caused by heat or hot surfaces.



DANGER!

This warning refers to the immediate danger when using this device in a hazardous atmosphere.



DANGER!

These warnings must be observed without fail. Even partial disregard of this warning can lead to serious health problems and even death. There is also the risk of seriously damaging the device or parts of the operator's plant.



WARNING!

Disregarding this safety warning, even if only in part, poses the risk of serious health problems. There is also the risk of damaging the device or parts of the operator's plant.



CAUTION!

Disregarding these instructions can result in damage to the device or to parts of the operator's plant.



INFORMATION!

These instructions contain important information for the handling of the device.



LEGAL NOTICE!

This note contains information on statutory directives and standards.



• **HANDLING**

This symbol designates all instructions for actions to be carried out by the operator in the specified sequence.

➔ **RESULT**

This symbol refers to all important consequences of the previous actions.

1.6 Safety instructions for the operator



WARNING!

In general, devices from the manufacturer may only be installed, commissioned, operated and maintained by properly trained and authorized personnel.

This document is provided to help you establish operating conditions, which will permit safe and efficient use of this device.

2.1 Scope of delivery

**INFORMATION!**

Do a check of the packing list to make sure that you have all the elements given in the order.

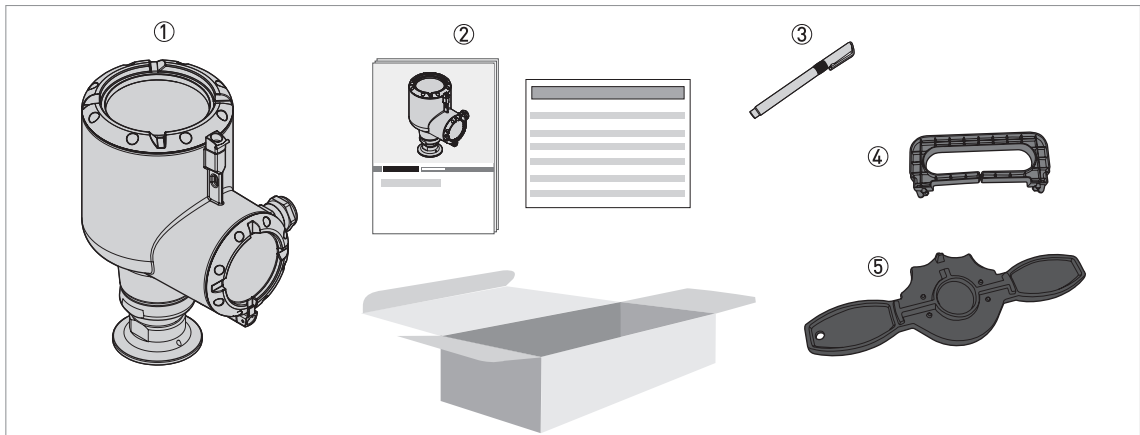

Figure 2-1: Scope of delivery

- ① Signal converter, process connection and antenna in the ordered version
- ② Quick Start and supplementary instructions (if the device has the appropriate options)
- ③ Bar magnet
- ④ Display extractor (for removal of the optional display module)
- ⑤ Cover wrench (for removal of the device covers)

2.2 Device description

This device is an 80 GHz FMCW-radar level transmitter. It is a non-contact technology and is 2-wire loop-powered. It is designed to measure the distance, level, mass, volume and reflectivity of liquids, pastes and slurries. For more data about the measuring principle, refer to *Measuring principle* on page 115.

Radar level transmitters use an antenna to emit a signal to the surface of the measured product. The device has many antennas available. Thus, it can measure most products even in difficult conditions. Also refer to *Technical data* on page 115.

If the device is ordered with the applicable options, it can be certified for use in hazardous areas.

The signal converter is attached directly to the process connection and the antenna. The illustration that follows shows the types of antenna.

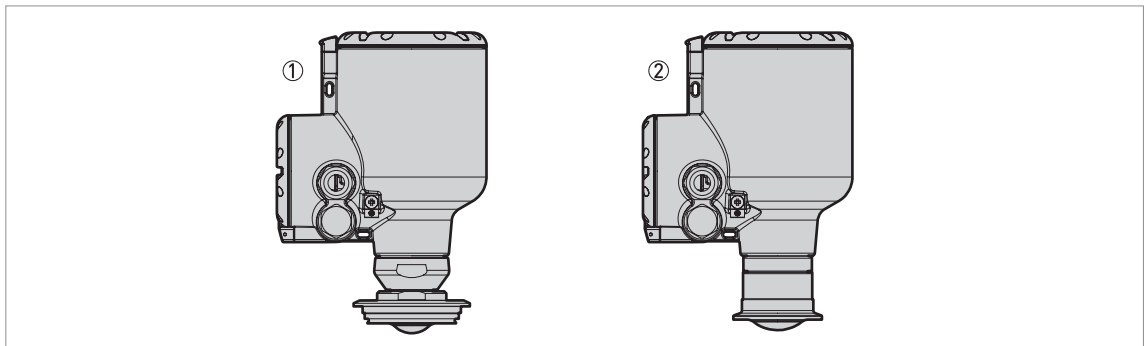

Figure 2-2: Types of antenna

- ① DN25 (1") Lens antenna made of PEEK.
- ② DN40 (1½") Lens antenna made of PEEK.



INFORMATION!

For more data about accessories, refer to *Accessories* on page 148.

2.3 Visual Check



WARNING!

If the display screen glass is broken, do not touch.



INFORMATION!

Inspect the packaging carefully for damages or signs of rough handling. Report damage to the carrier and to the local office of the manufacturer.

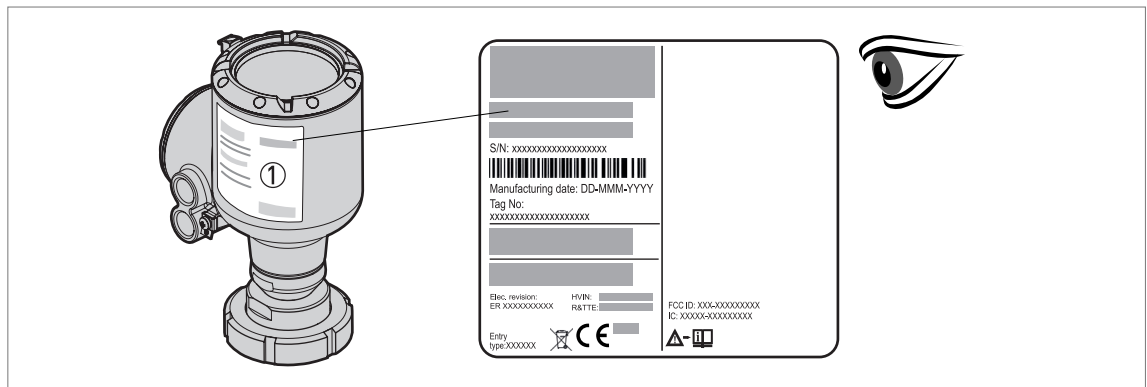

Figure 2-3: Visual check

① Device nameplate (for more data refer to *Nameplate (examples)* on page 20)



INFORMATION!

Look at the device nameplate to ensure that the device is delivered according to your order. Check for the correct supply voltage printed on the nameplate.

2.4 Nameplates



INFORMATION!

Look at the device nameplate to ensure that the device is delivered according to your order. Check for the correct supply voltage printed on the nameplate.

2.4.1 Nameplate (examples)

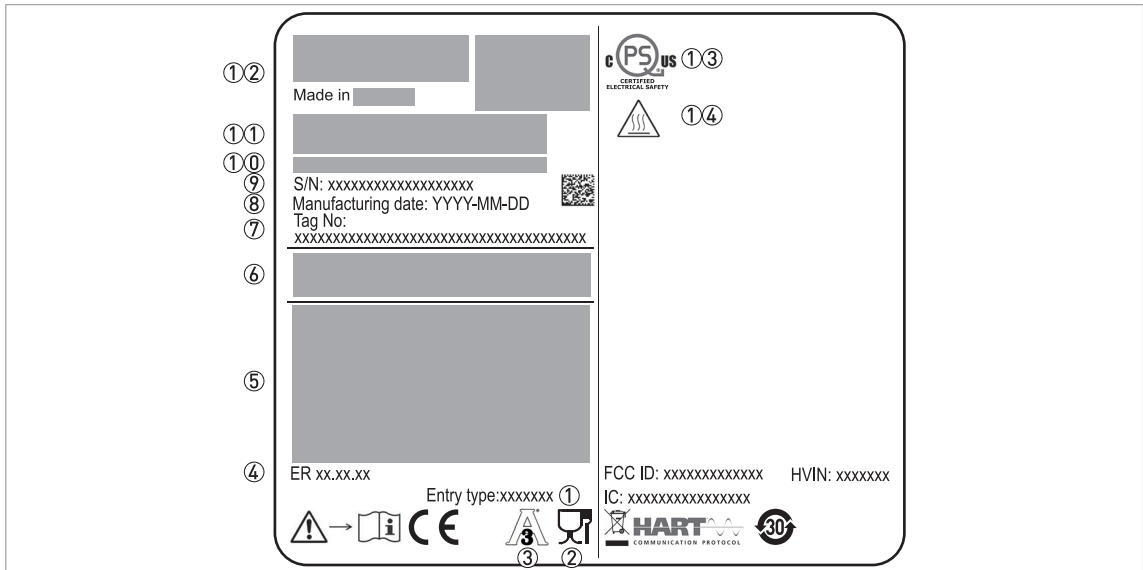

Figure 2-4: Non-Ex nameplate attached to the housing

- ① Cable entry size
- ② EU food contact symbol. The device agrees with the related EU sanitary regulations. For more data, refer to *Technical data* on page 117.
- ③ Optional 3-A® approval. Devices with this symbol agree with 3-A® sanitary standards for design and fabrication.
- ④ Electronic revision (according to NAMUR NE 53)
- ⑤ Signal output (analog, HART®, fieldbus, etc.), input voltage and maximum current (fieldbus options: basic current)
- ⑥ Degree of ingress protection (according to EN 60529 / IEC 60529)
- ⑦ Hycontrol reference code
- ⑧ Date of manufacture
- ⑨ Serial number
- ①① Type code [defined in order]. For more data.
- ①① Model name and number. C = compact version.
- ①② Company logo, name and postal address
Country of manufacture / Company web address
- ①③ cQPUS electrical safety certification for the USA and Canada. Agrees with NEC and CEC requirements for installation in ordinary locations.
- ①④ WARNING! Hot surface. If the device is connected to tank that operates at high temperature, there is a risk of injury.

3.1 General notes on installation

**INFORMATION!**

Inspect the packaging carefully for damages or signs of rough handling. Report damage to the carrier and to the local office of the manufacturer.

**INFORMATION!**

Do a check of the packing list to make sure that you have all the elements given in the order.

**INFORMATION!**

Look at the device nameplate to ensure that the device is delivered according to your order. Check for the correct supply voltage printed on the nameplate.

3.2 Storage

**WARNING!**

Do not keep the device in a vertical position. This will damage the antenna and the device will not measure correctly.

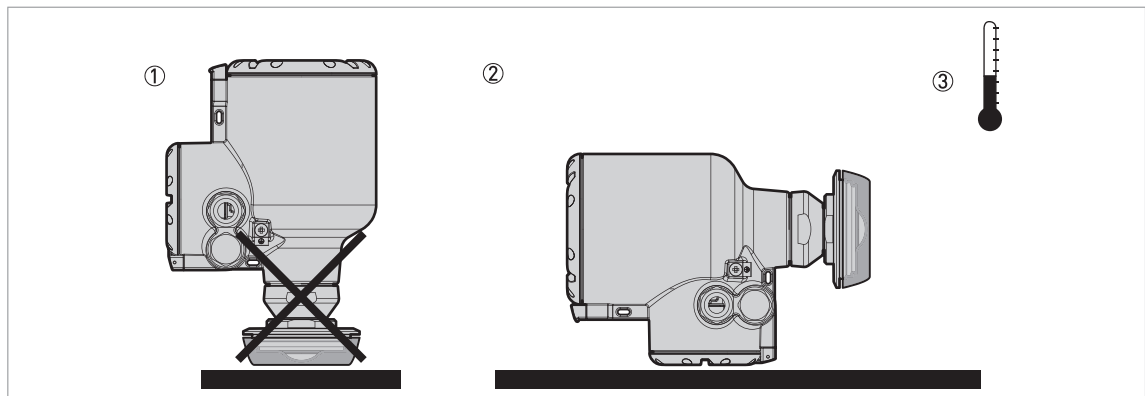

Figure 3-1: Storage conditions

- ① When you put the device into storage, do not keep it in a vertical position.
- ② Put the device on its side. We recommend that you use the packaging in which it was delivered.
- ③ Storage temperature range: -40...+85°C / -40...+185°F

- Store the device in a dry and dust-free location.
- Keep the converter out of the sunlight.
- Store the device in its original packing.

3.3 Transport

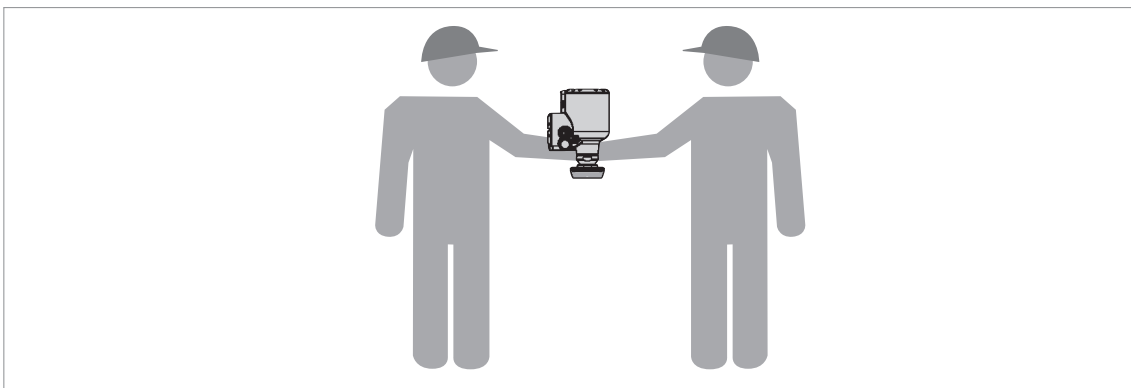

Figure 3-2: How to lift the device



WARNING!

Lift the device carefully to prevent damage to the PEEK antenna and polished parts.

3.4 Pre-installation requirements



INFORMATION!

Obey the precautions that follow to make sure that the device is correctly installed.

- Make sure that there is sufficient space on all sides.
- Protect the signal converter from direct sunlight. If necessary, install the weather protection accessory.
- Do not subject the signal converter to heavy vibrations. The devices are tested for vibration and agree with EN 50178 and IEC 60068-2-6.

3.5 Pressure and temperature ranges



WARNING!

The process connection temperature range must agree with the temperature limits of the gasket material. The operating pressure range is subject to the process connection used and the flange temperature.

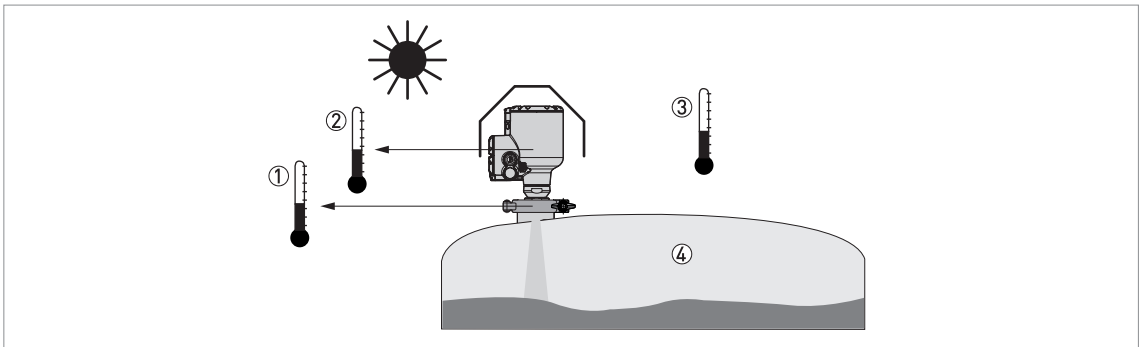

Figure 3-3: Pressure and temperature ranges

- ① Temperature at the process connection
Non-Ex devices: The temperature range depends on the type of antenna, process connection and the seal material. Refer to the table that follows.
Devices with Hazardous Location approvals: see supplementary instructions
- ② Ambient temperature for operation of the display
-20...+70°C / -4...+158°F
If the ambient temperature is not between these limits, then it is possible that the display screen will not operate temporarily. The device continues to measure level and send an output signal.
- ③ Ambient temperature
Non-Ex devices: -40...+80°C / -40...+176°F
Devices with Hazardous Location approvals: see supplementary instructions
- ④ Process pressure
Depends on the type of antenna and process connection. Refer to the table that follows.

Maximum process connection temperature and operating pressure

Antenna type	Options	Maximum process connection temperature		Maximum operating pressure	
		[°C]	[°F]	[barg]	[psig]
Lens DN25 (1"), PEEK	DN50 VARIVENT® Type N adaptor	+150	+302	10	145
Lens DN25 (1"), PEEK	DN50 DIN 11851 adaptor; SMS 51	+150	+302	25	362
Lens DN25 (1"), PEEK	DN40 DIN 11851 adaptor; DIN 11864-1; Tri-Clamp®	+150	+302	40	580
Lens DN40 (1½"), PEEK	2" Tri-Clamp®; DN50 NEUMO BioControl®	+150	+302	40	580

3.6 Recommended mounting position



CAUTION!

Follow these recommendations to make sure that the device measures correctly. They have an effect on the performance of the device.

We recommend that you prepare the installation when the tank is empty.

3.6.1 General notes

Recommended nozzle position for liquids, pastes and slurries

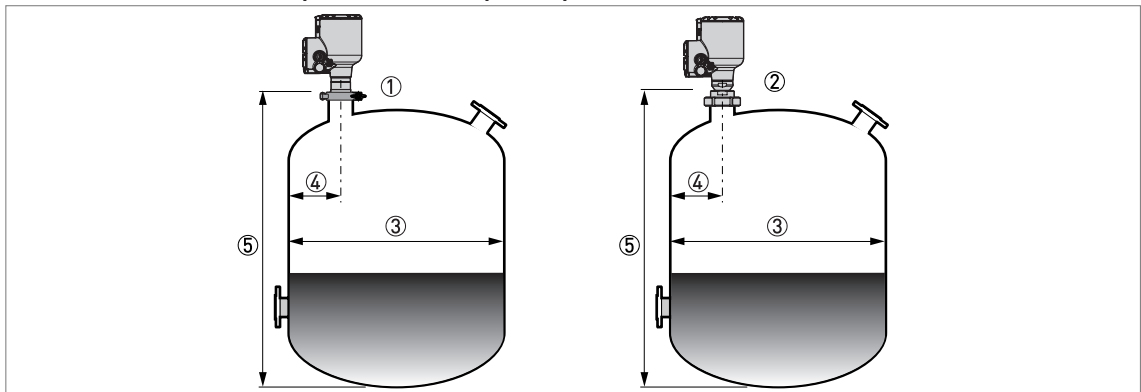

Figure 3-4: Recommended nozzle position for liquids, pastes and slurries

- ① Socket for the DN25 (1") Lens antenna
- ② Socket for the DN40 (1½") Lens antenna
- ③ Tank diameter
- ④ Minimum distance of the nozzle or socket from the tank wall (depends on the antenna type and size – refer to items ① and ② in this list):
 - DN25 (1") Lens : $1/5 \times$ tank height
 - DN40 (1½") Lens: $1/10 \times$ tank height
 Maximum distance of the nozzle or socket from the tank wall (depends on the antenna type and size – refer to items ① and ② in this list):
 - Lens: $1/3 \times$ tank diameter
- ⑤ Tank height



INFORMATION!

If there is a nozzle on the tank before installation, the nozzle must be a minimum of 200 mm / 7.9" from the tank wall. The tank wall must be flat and there must not be obstacles adjacent to the nozzle or on the tank wall.

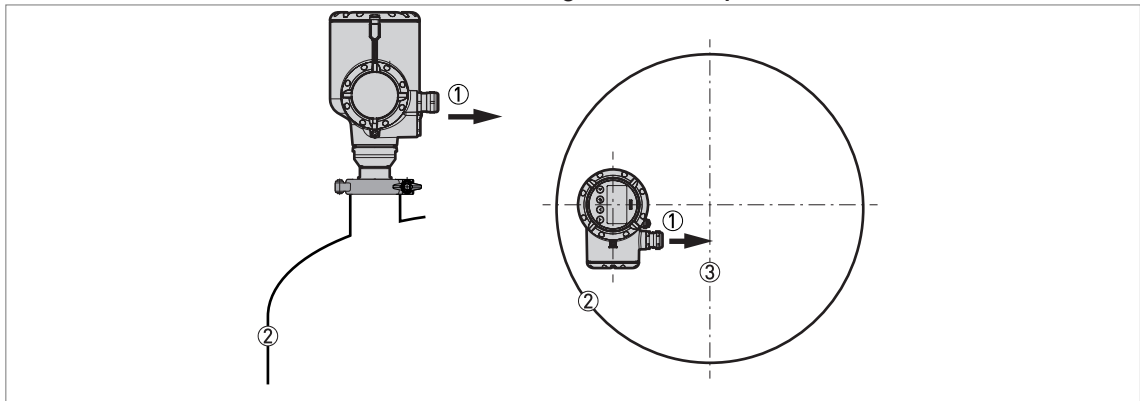
Point the device in the correct direction to get the best performance**Figure 3-5: Point the device in the correct direction to get the best performance**

- ① Cable entry
- ② Nearest tank wall
- ③ Tank centerline

Point the cable entries on the housing in the direction of the tank centerline.

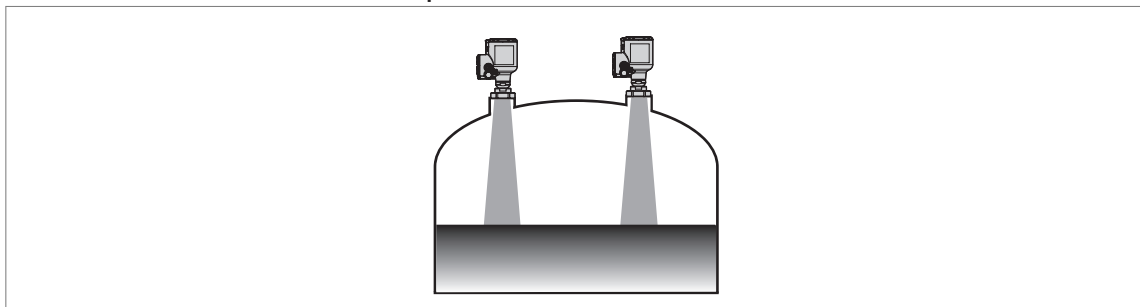
Number of devices that can be operated in a tank**Figure 3-6: There is no maximum limit to the number of devices that can be operated in the same tank**

There is no maximum limit to the number of devices that can be operated in the same tank. They can be installed adjacent to other radar level transmitters.

3.6.2 Tanks with dish-shaped and conical bottoms

Dish-shaped or conical bottoms have an effect on the measuring range. The device cannot measure to the bottom of the tank. If possible, install the device as shown in the illustration that follows:

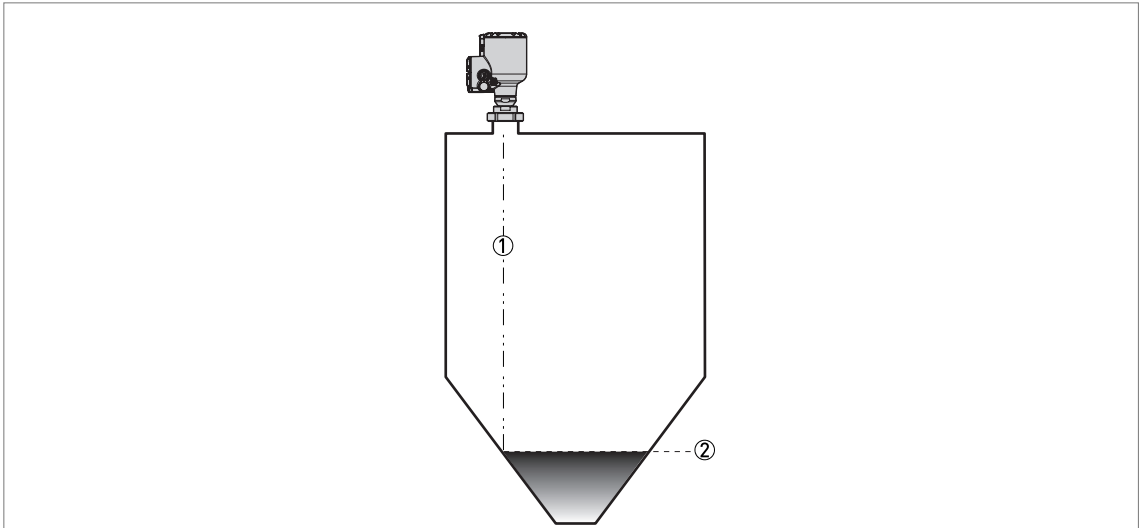

Figure 3-7: Tanks with dish-shaped or conical bottoms

- ① Axis of radar beam
- ② Minimum level reading

3.7 Mounting restrictions

**CAUTION!**

Follow these recommendations to make sure that the device measures correctly. They have an effect on the performance of the device.

We recommend that you prepare the installation when the tank is empty.

3.7.1 General notes

LPR and TLPR devices

**WARNING!**

LPR (Level Probing Radar) devices measure level in the open air or in a closed space (a metallic tank etc.). TLPR (Tank Level Probing Radar) devices measure level in a closed space only. You can use LPR devices for TLPR applications. For more data, refer to Radio approvals on page 8.

Causes of interference signals

- Objects in the tank or pit.
- Sharp corners that are perpendicular to the path of the radar beam.
- Sudden changes in tank diameter in the path of the radar beam.

**CAUTION!**

Do not install the device above objects in the tank (agitator etc.) or pit. Objects in the tank or pit can cause interference signals. If there are interference signals, the device will not measure correctly.

If it is not possible to install the device on another part of the tank or pit, do an empty spectrum scan. For more data, refer to Empty spectrum recording on page 92.

Equipment and obstacles: how to prevent measurement of interference signals

Do not put the device immediately above equipment and obstacles in a tank or pit. This can have an effect on the performance of the device.

**INFORMATION!**

If possible, do not install a nozzle on the tank centerline.

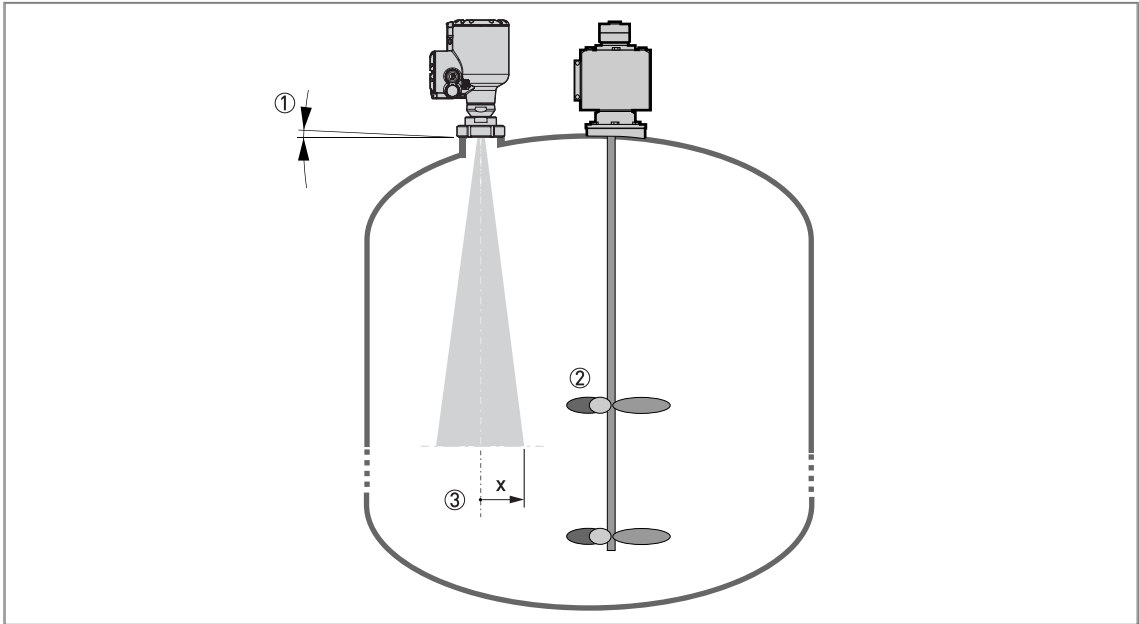

Figure 3-8: Equipment and obstacles: how to prevent measurement of interference signals

- ① Do not tilt the device more than 2°
- ② We recommend that you do an empty spectrum recording if there are too many obstacles in the radar beam (for more data, refer to *Empty spectrum recording* on page 92).
- ③ Beam radius of the antenna: refer to the table below. The beam radius increases by increments of "x" mm for each metre of distance from the antenna.

Beam radius of the antenna

Antenna type	Beam angle	Beam radius, x	
		[mm/m]	[in/ft]
Lens, DN25 (1")	10°	87	1.0
Lens, DN40 (1½")	8°	70	0.8

Product inlets

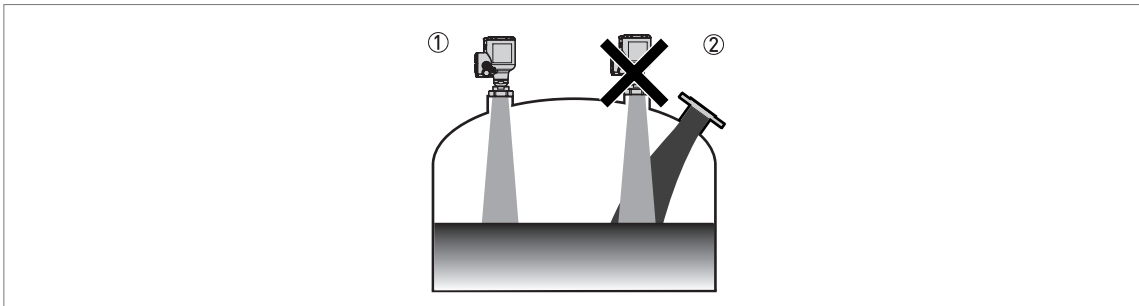

Figure 3-9: Product inlets

- ① The device is in the correct position.
- ② The device is too near to the product inlet.

**CAUTION!**

Do not put the device near to the product inlet. If the product that enters the tank touches the antenna, the device will measure incorrectly. If the product fills the tank directly below the antenna, the device will also measure incorrectly.

**INFORMATION!**

For more data about the measuring range of each type of antenna, refer to Measuring accuracy on page 122.

3.7.2 Process connections

Requirements for hygienic connections: General notes

**WARNING!****Installation conditions for EHEDG-approved devices**

- To prevent contamination of the tank contents by microorganisms, make sure that the bottom of the antenna is flush with the inner surface of the tank.
- The antenna must be accessible for cleaning.
- Process seals must agree with EHEDG guidelines. Refer to the Position Paper of the EHEDG Test Institutes Working Group: "Easy cleanable Pipe couplings and Process connections" on this website: <https://www.ehedg.org/>. Go to Guidelines > Free Documents, find "EHEDG Position Paper" in the list of documents and make a selection from the language options.
- Make sure that you do not damage parts made of PEEK, polished parts and the O-ring. Use standard CIP-SIP process conditions. Make sure that the antenna, gaskets and other process seals are resistant to the tank contents and the product used for the cleaning process.

**WARNING!****Installation conditions for 3-A®-approved devices**

- To prevent contamination of the tank contents by microorganisms, make sure that the bottom of the antenna is flush with the inner surface of the tank.
- Make sure that the position of the device permits liquid to drain from the antenna.
- The antenna must be accessible for cleaning.
- Process connections must agree with 3-A® Sanitary Standards. Refer to 3-A® Sanitary Standard for Sensors and Sensor Fittings and Connections, Number 74-06.
- Process seals must agree with 3-A® Sanitary Standards. Refer to 3-A® Sanitary Standard for Multiple-Use Rubber and Rubber-Like Materials Used as Product Contact Surfaces in Dairy Equipment, Number 18-03. Refer also to 3-A Sanitary Standards for Sanitary fittings, Number 63-03 and 3-A CCE Coordination Bulletin, Number 2011-3 (DIN Standard Fittings Compliance).
- Make sure that you do not damage parts made of PEEK, polished parts and the O-ring. Use standard CIP-SIP process conditions. Make sure that the antenna, gaskets and other process seals are resistant to the tank contents and the product used for the cleaning process.

**INFORMATION!****Nozzles and sockets**

To make the cleaning of the antenna easier, attach the device to a short process connection. The height of the process connection must be equal or less than its diameter.

BioControl® (hygienic) connections: installation procedure

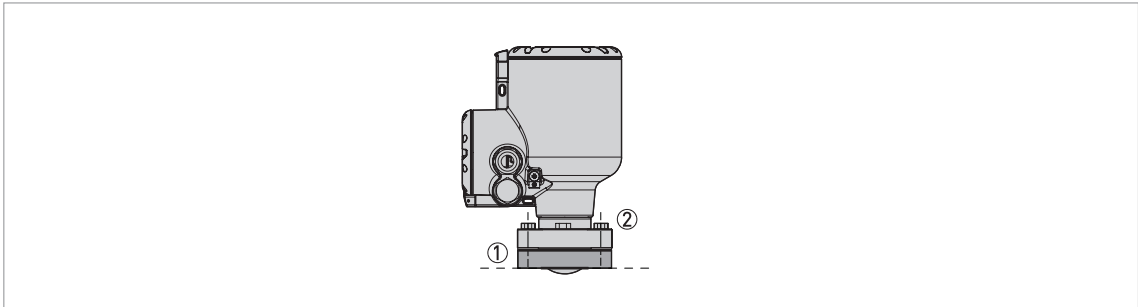

Figure 3-10: BioControl® connection: installation procedure

- ① BioControl® connection on the tank
- ② Flange bolts

Equipment needed:

- Device
- Gasket
- Flange bolts (not supplied)
- Wrench (not supplied)



How to attach a device with a Biocontrol® connection

- Make sure that the flange on the nozzle is level.
- Make sure that you use the applicable gasket for the flange dimensions and the process.
- Align the gasket correctly with the flange facing of the nozzle.
- Carefully put the device on the tank process connection.
- Tighten the flange bolts.
- ➡ Refer to local rules and regulations for the correct torque to apply to the bolts.

Tri-Clamp® (hygienic) connections: installation procedure

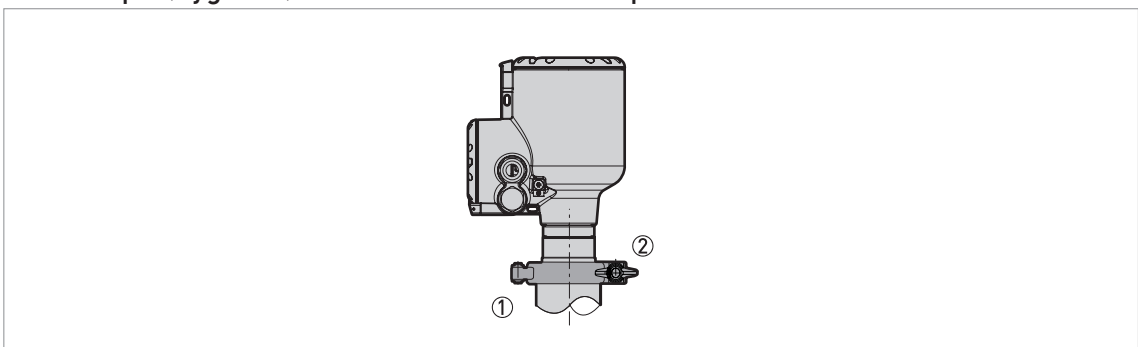

Figure 3-11: Tri-Clamp® connection: installation procedure

- ① Tank socket
- ② Clamp



WARNING!

EHEDG-approval

You can only use EHEDG-approved devices that have a Tri-Clamp® connection with a Combifit T-seal.

Equipment needed:

- Device
- Gasket (not supplied)
- Clamp (not supplied)

**How to attach a device with a Tri-Clamp® connection**

- Make sure that the tank connection is level.
- Make sure that you use the applicable gasket for the connection dimensions and the process.
- Align the gasket correctly.
- Carefully put the device on the tank process connection.
- Attach the clamp to the process connection.
- Tighten the clamp.

DIN 11851 (hygienic) connections: installation procedure

Figure 3-12: DIN 11851 connection: installation procedure

- ① Tank socket
- ② Union nut for DIN 11851 connection

**WARNING!**

You can only use EHEDG-approved devices that have a DIN 11851 connection with:

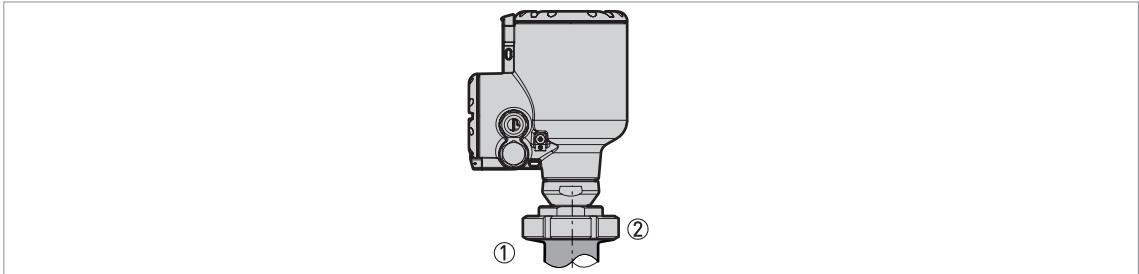
- an **ASEPTO-STAR, type k-flex upgrade** gasket from Kieselmann GmbH, or
- an **EPDM or FKM/FPM inner gasket** from SKS B.V.

Equipment needed:

- Device
- Gasket (not supplied)
- DIN 11851 union nut

**How to attach a device with a DIN 11851 connection**

- Make sure that the tank connection is level.
- Make sure that you use the applicable gasket for the connection dimensions and the process.
- Align the gasket correctly.
- Carefully put the device on the tank process connection.
- Turn the nut on the device process connection to attach the device to the tank.
- Tighten the connection.
- ➡ Refer to local rules and regulations for the correct torque to apply to the connection.

DIN 11864-1 (hygienic) connections: installation procedure

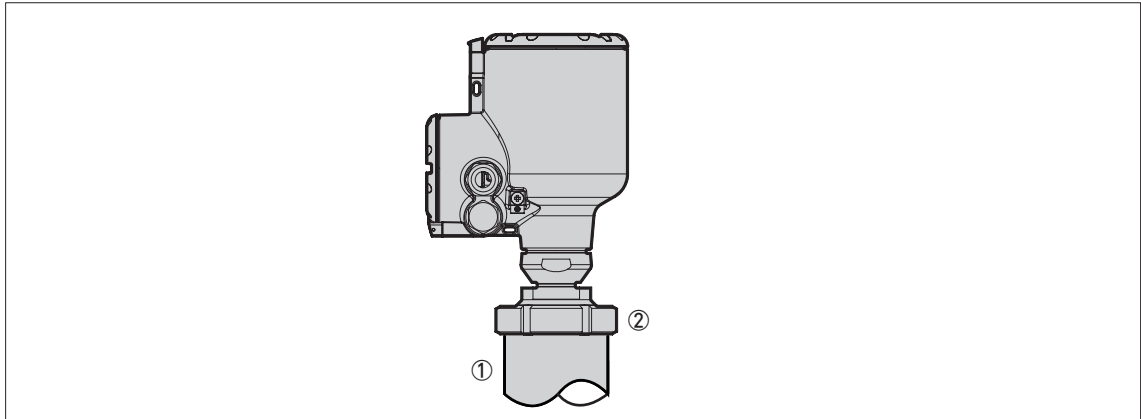

Figure 3-13: DIN 11864-1 connection: installation procedure

- ① Tank socket
- ② Union nut for DIN 11864-1 connection



INFORMATION!

DIN 11864-1 Form A agrees with EHEDG design criteria.

Equipment needed:

- Device
- O-Ring for Form A (not supplied)
- DIN 11864-1 union nut



How to attach a device with a DIN 11864-1 connection

- Make sure that the tank connection is level.
- Make sure that you use the applicable gasket for the connection dimensions and the process.
- Align the gasket correctly.
- Carefully put the device on the tank process connection.
- Turn the nut on the device process connection to attach the device to the tank.
- Tighten the connection.
- ➡ Refer to local rules and regulations for the correct torque to apply to the connection.

SMS connections: installation procedure

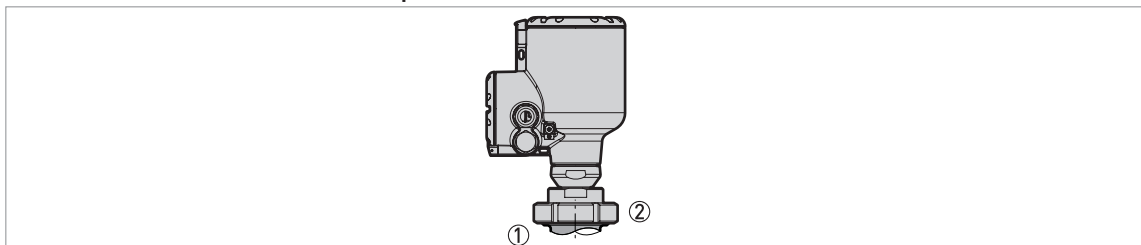

Figure 3-14: SMS connection: installation procedure

- ① Tank socket
- ② Union nut for SMS connection

**INFORMATION!**

The SMS connection does not agree with 3-A® and EHEDG sanitary design standards.

Equipment needed:

- Device
- Gasket (not supplied)
- SMS union nut

**How to attach a device with a SMS connection**

- Make sure the tank connection is level.
 - Make sure that you use the applicable gasket for the connection dimensions and the process.
 - Align the gasket correctly.
 - Carefully put the device on the tank process connection.
 - Turn the nut on the device process connection to attach the device to the tank.
 - Tighten the connection.
- ➡ Refer to local rules and regulations for the correct torque to apply to the connection.

VARIVENT® (hygienic) connections: installation procedure

Figure 3-15: VARIVENT® connection: installation procedure

- ① Tank socket (VARIVENT® Access Unit – not supplied)
- ② Clamp

**WARNING!**

You can only use EHEDG-approved devices that have a VARIVENT® connection with an EPDM O-ring.

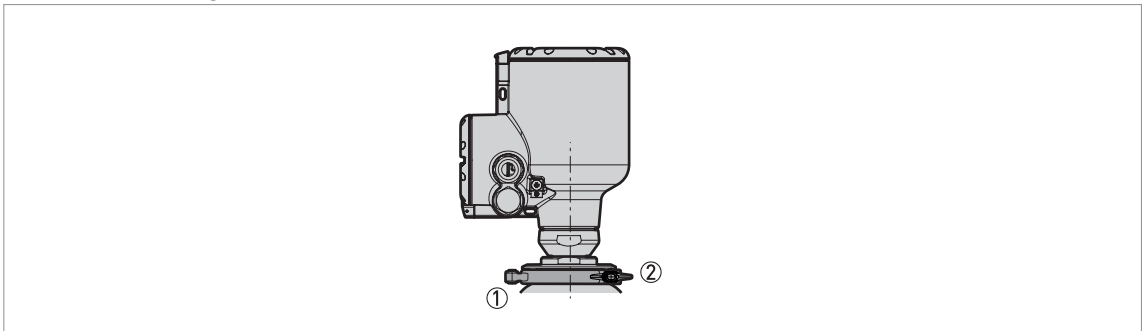
Equipment needed:

- Device with a VARIVENT® adaptor
- Clamp (not supplied)

**How to attach a device with a VARIVENT® connection**

- Make sure the tank connection is level.
- Carefully put the device with a VARIVENT® adaptor on the tank process connection.
- Attach the clamp to the process connection.
- Tighten the clamp.

3.8 How to turn or remove the display module (option)

If there is an object adjacent to the device that makes it difficult to read the display, you can rotate the display in increments of 90°.

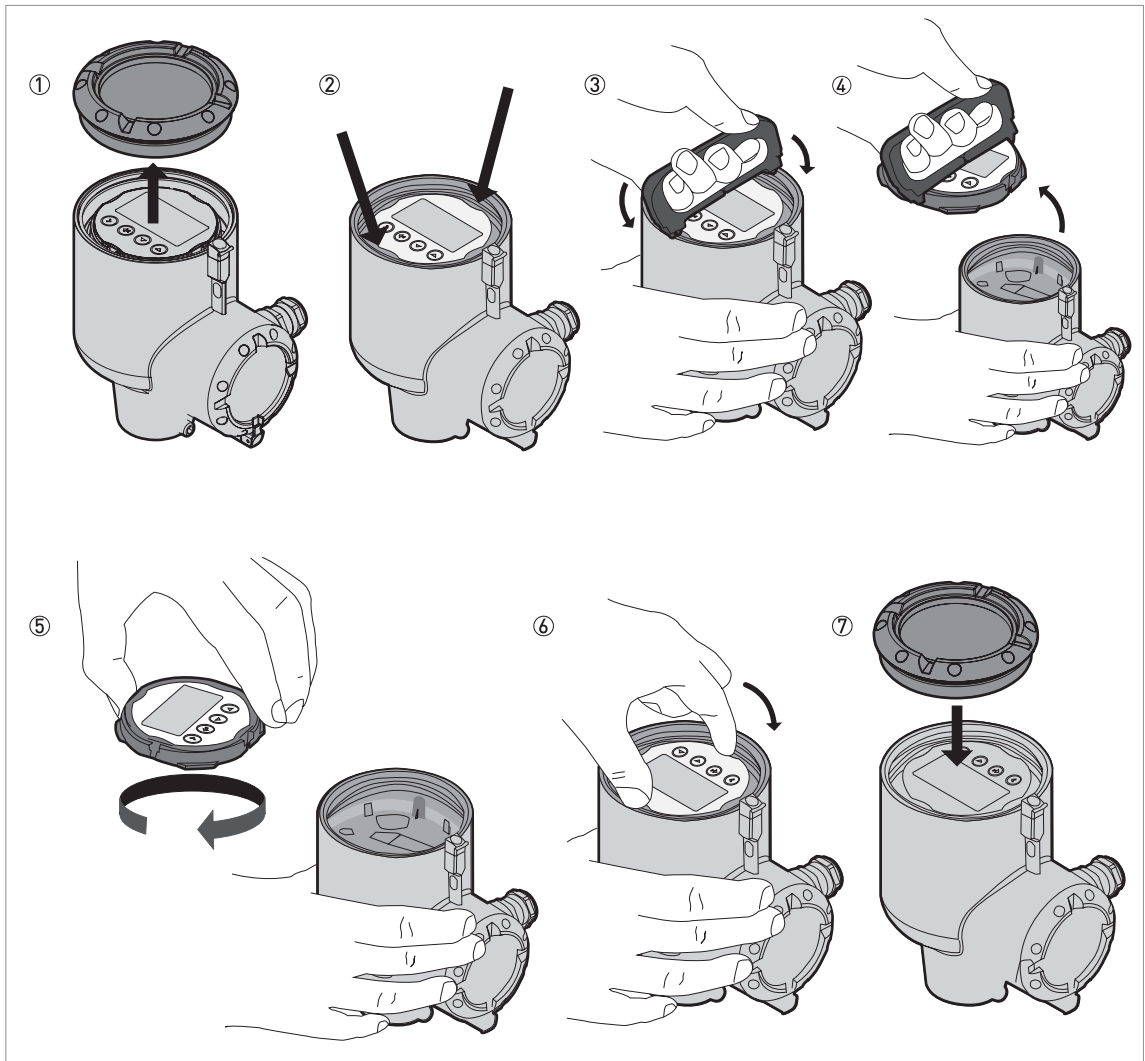

Figure 3-16: How to turn or remove the display module (option)

Equipment needed:

- Cover wrench
- Display extractor



CAUTION!
Disconnect the power supply.



Follow this procedure:

- Remove the housing cover with the cover wrench.
- Find the two clips that hold the display module in the housing.

- Use the display extractor to remove the display module from the housing. Put the display extractor in the slots on the module for these clips.
 - Carefully remove the display module from housing and then remove the display extractor from the display module.
 - Turn the display module until it points to the user.
 - Put the display module back on the electronics block. If the clips make a click, then the display module is correctly attached to the electronics block.
 - Make sure that the housing cover has a gasket. Attach the cover to the housing and tighten it by hand.
- ➡ End of the procedure.



INFORMATION!

The cover wrench and display extractor are supplied with the device. If it is necessary to send an order for the cover wrench or the display extractor, refer to Accessories on page 148.

3.9 Weather protection

3.9.1 How to attach the weather protection to the device



Figure 3-17: Equipment needed to assemble the weather protection

- ① Weather protection cover (with an R-clip to hold the cover on the clamp)
- ② Device
- ③ Weather protection clamp (2 parts)
- ④ 2 locking nuts
- ⑤ 10 mm socket wrench (not supplied)

The overall dimensions of the weather protection are on page 126.

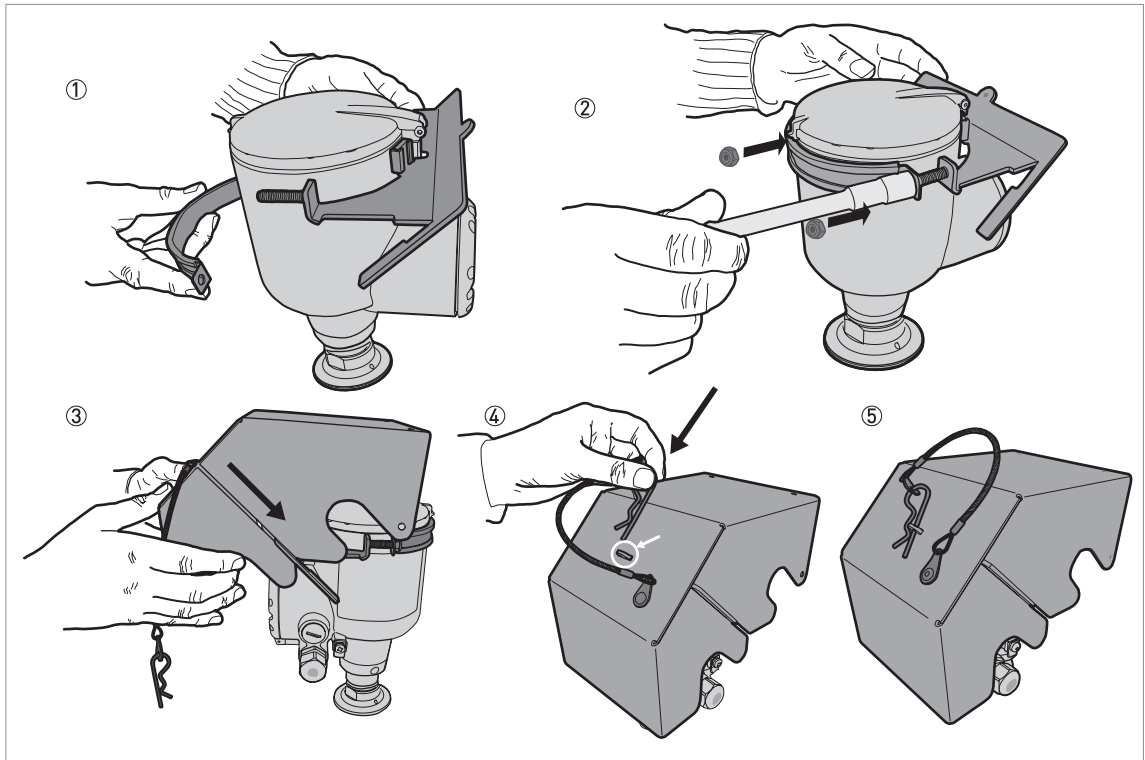

Figure 3-18: Installation of the weather protection



- ① Put the weather protection clamp around the top of the device.
- ② Attach the two locking nuts to the threads on the weather protection clamp. Tighten the locking nuts with a 10 mm socket wrench.
- ③ Lower the weather protection cover onto weather protection clamp until the hole for the lock is in the slot at the front of the cover.
- ④ Put the R-clip into the hole at the front of the weather protection cover.
- ⑤ End of the procedure.

3.9.2 How to open the weather protection

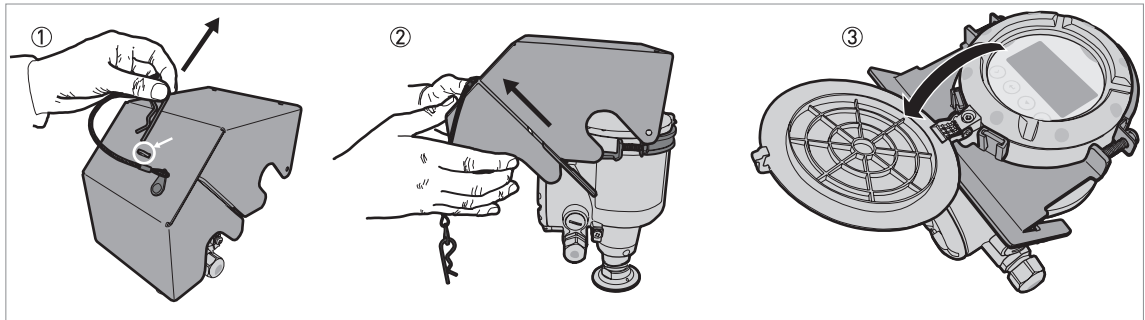

Figure 3-19: How to open the weather protection



- ① Remove the R-clip from the hole at the front of the weather protection cover.
- ② Remove the weather protection cover.
- ③ Lift the display screen cover. End of the procedure.

4.1 Safety instructions

**DANGER!**

All work on the electrical connections may only be carried out with the power disconnected.
Take note of the voltage data on the nameplate!

**DANGER!**

Observe the national regulations for electrical installations!

**DANGER!**

For devices used in hazardous areas, additional safety notes apply; please refer to the Ex documentation.

**WARNING!**

Observe without fail the local occupational health and safety regulations.
Any work done on the electrical components of the measuring device may only be carried out by properly trained specialists.

**INFORMATION!**

Look at the device nameplate to ensure that the device is delivered according to your order.
Check for the correct supply voltage printed on the nameplate.

4.2 General notes

This chapter includes electrical connection data about devices with the 4...20 mA output and HART® communication options. These are 2-wire, loop-powered devices.

**INFORMATION!****Devices with the FOUNDATION™ fieldbus output option:**

For electrical connection data, refer to the "Description of FOUNDATION™ fieldbus interface" supplementary instructions.

**INFORMATION!****Devices with the PROFIBUS PA output option:**

For electrical connection data, refer to the "Description of PROFIBUS PA interface" supplementary instructions.

4.3 Electrical installation: output options with cable gland

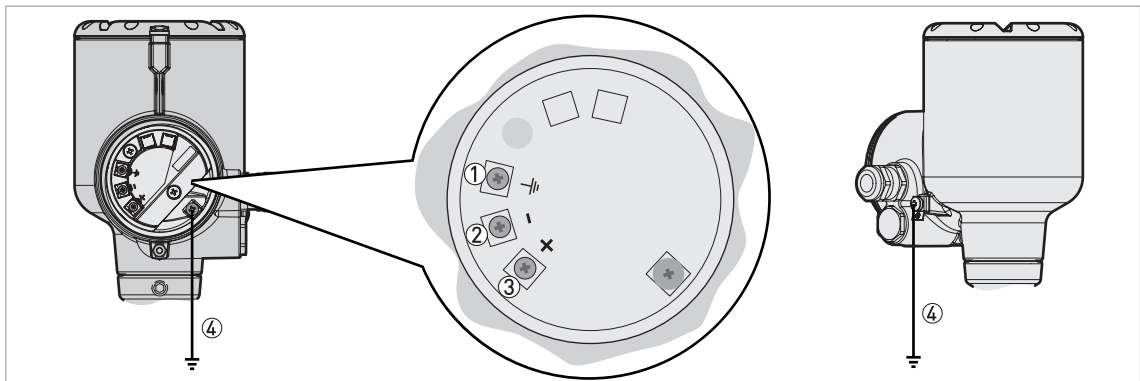

Figure 4-1: Terminals for electrical installation: standard cable gland

- ① Grounding terminal in the housing (if the electrical cable is shielded)
- ② Current output -
- ③ Current output +
- ④ Location of the external grounding terminal (at the bottom of the converter)



INFORMATION!

Electrical power to the output terminal energizes the device. The output terminal is also used for HART® communication.



CAUTION!

- Use the applicable electrical cables with the cable glands.
- Make sure that the current is not more than 5 A or that there is 5 A-rated fuse in the electrical circuit that energizes the device.

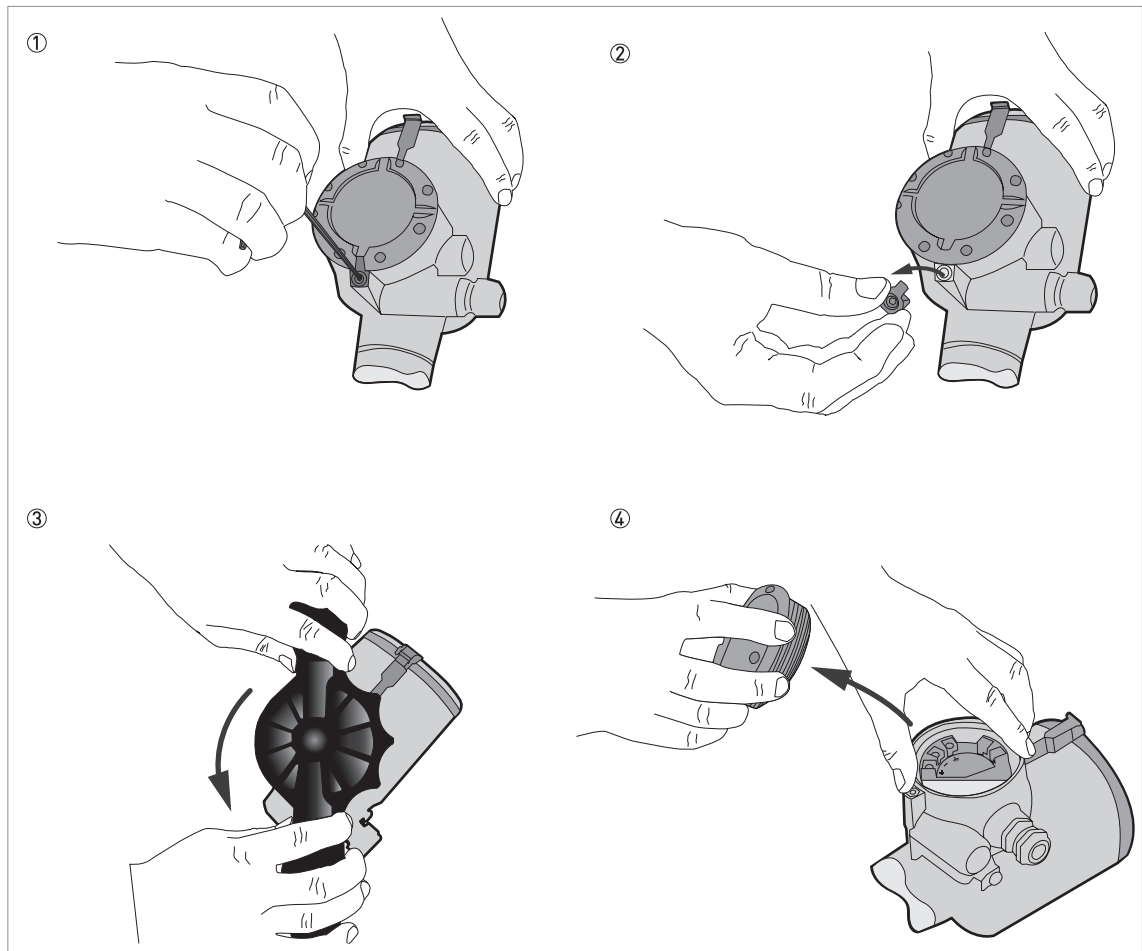

Figure 4-2: How to open the terminal compartment cover

Equipment needed:

- 3 mm Allen wrench (not supplied)
- Cover wrench



Procedure

- ① Loosen the lock screw with a 3 mm Allen wrench.
- ② Remove the cover stop.
- ③ Turn the cover counterclockwise with the cover wrench.
- ④ Remove the cover.

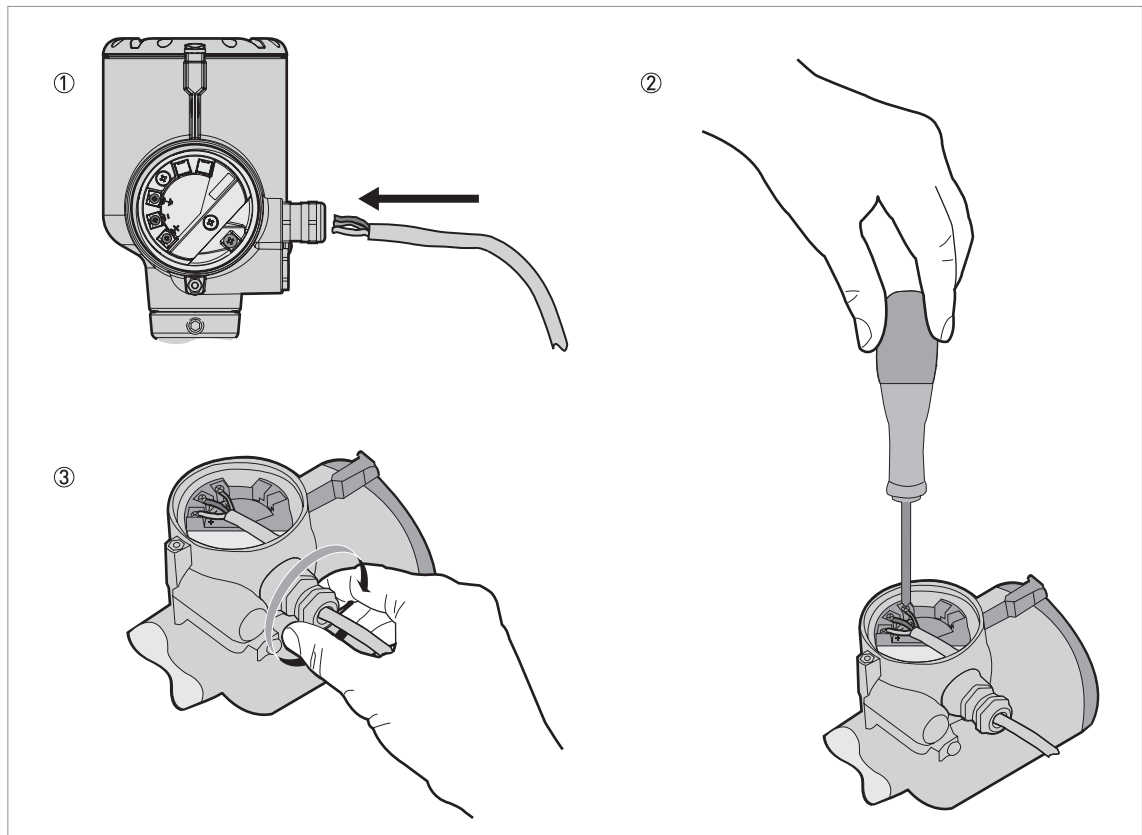

Figure 4-3: Procedure for electrical installation

Equipment needed:

- POZIDRIV® PZ1 screwdriver (not supplied)



Procedure

- ① Loosen the cable gland. Put the electrical wires into the cable entry. Loosen the terminal screws with a POZIDRIV® PZ1 screwdriver. Connect the electrical wires to the connector.
- ② Tighten the terminal screws with a POZIDRIV® PZ1 screwdriver.
- ③ Tighten the cable gland.

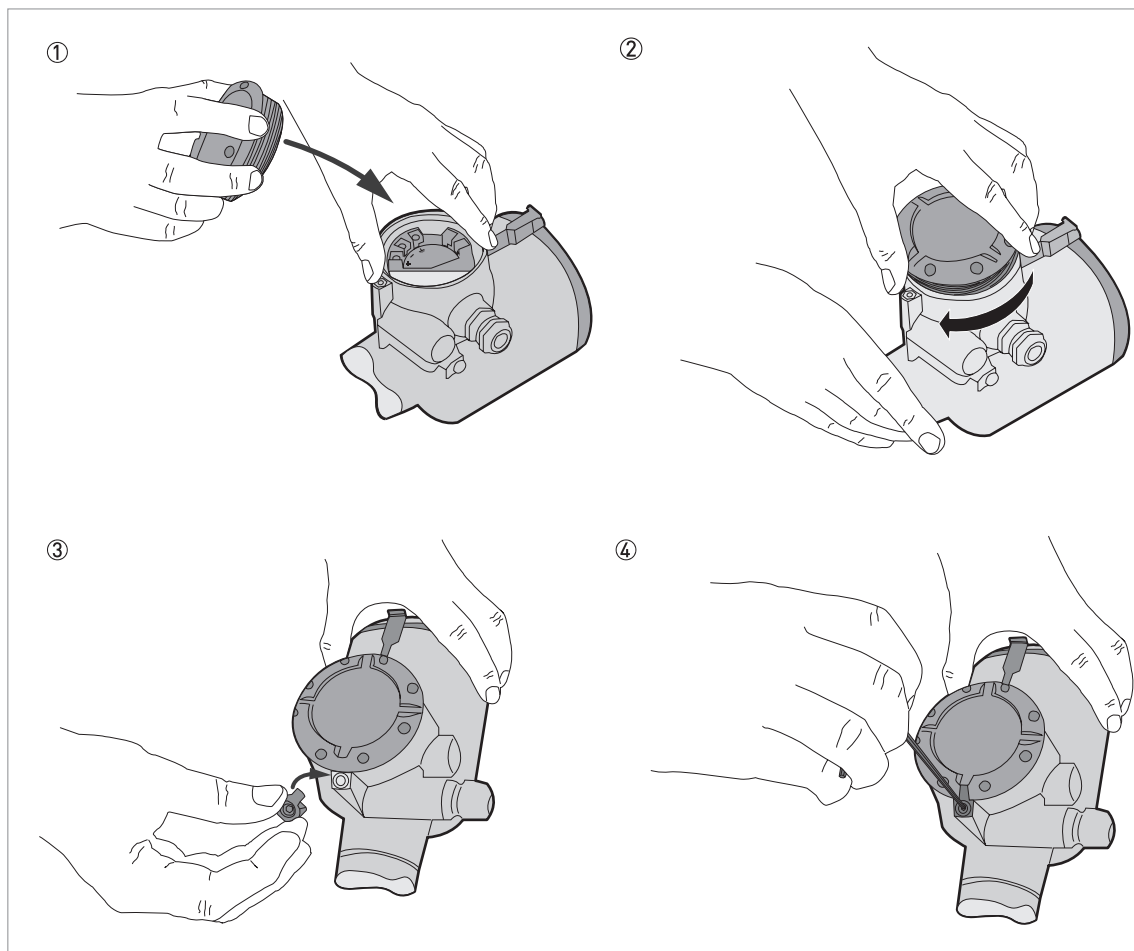

Figure 4-4: How to close the terminal compartment cover

Equipment needed:

- 3 mm Allen wrench (not supplied)



- ① Put the cover on the housing
- ② Turn the cover clockwise until it is fully engaged.
- ③ Attach the cover stop and lock screw.
- ④ Tighten the lock screw with a 3 mm Allen wrench.

4.4 Electrical installation: output options with an M12 male connector

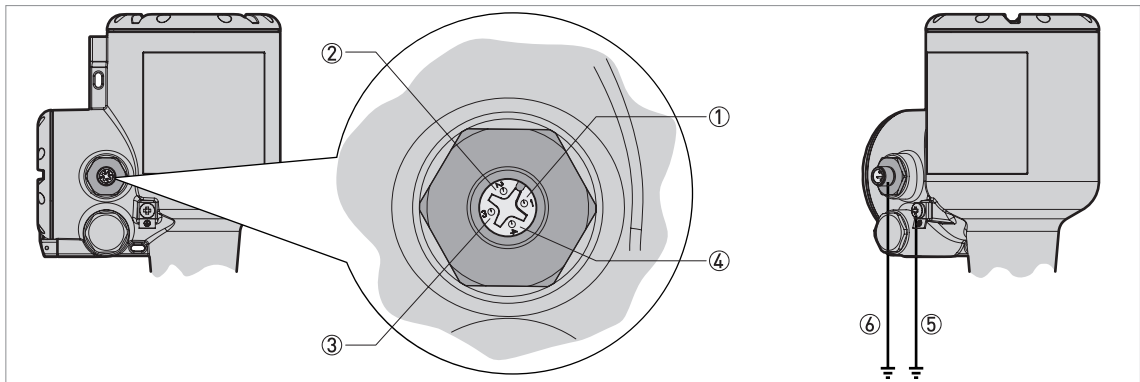

Figure 4-5: Terminals for electrical installation: 4-pin male M12 connector

- ① Pin 1: current output +
- ② Pin 2: not connected
- ③ Pin 3: current output -
- ④ Pin 4: not connected
- ⑤ Grounding terminal (external thread of the connector)
- ⑥ Location of the external grounding terminal (at the bottom of the converter)



INFORMATION!

Electrical power to the output terminal energizes the device. The output terminal is also used for HART® communication.

4.5 Electrical connection for current output

4.5.1 Non-Ex devices

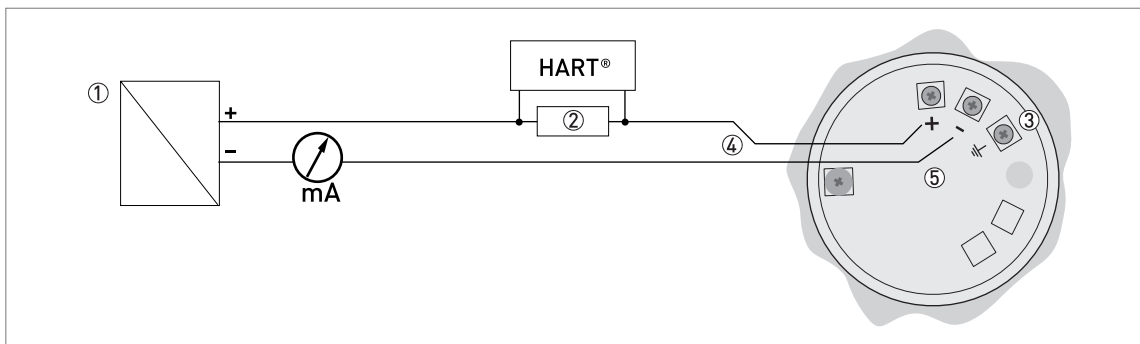

Figure 4-6: Electrical connections for non-Ex devices

- ① Power supply
- ② Resistor for HART® communication (typically 250 ohms)
- ③ Optional connection to the grounding terminal
- ④ Output: 12...30 VDC for an output of 21.5 mA at the terminal
- ⑤ Device

4.5.2 Devices for hazardous locations



DANGER!

For electrical data for device operation in hazardous locations, refer to the related certificates of compliance and supplementary instructions (ATEX etc.). This documentation can be downloaded from the website.

4.6 Ingress protection



INFORMATION!

The ingress protection of the device agrees with the conditions that are necessary for IP66 / IP68 (0.1 barg / 1.45 psig), as given in International Standard IEC 60529.



DANGER!

Make sure that the cable gland is watertight.

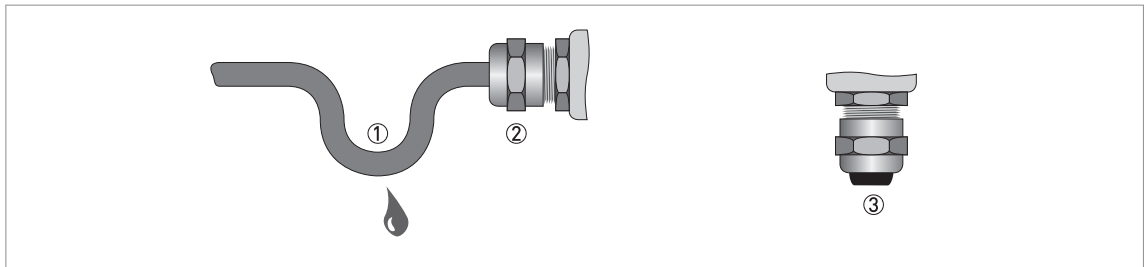

Figure 4-7: How to make the installation agree with protection category IP68



- Make sure that the gaskets are not damaged.
- Make sure that the electrical cables are not damaged.
- Make sure that the electrical cables agree with the national electrical code.
- The cables are in a loop in front of the device ① so water does not go into the housing.
- Tighten the cable glands ②.
- Close unused cable glands with dummy plugs ③.

The diameter of the outer sheath of the electrical cable (for the power supply and current output) must be 6...10 mm or 0.24...0.39".

4.7 Networks

4.7.1 General information

The device uses the HART® communication protocol. This protocol agrees with the HART® Communication Foundation standard. The device can be connected point-to-point. It can also have a polling address of 1 to 63 in a multi-drop network.

The device output is factory-set to communicate point-to-point. To change the communication mode from **point-to-point** to **multi-drop**, refer to *HART®* network configuration on page 94.

4.7.2 Point-to-point connection

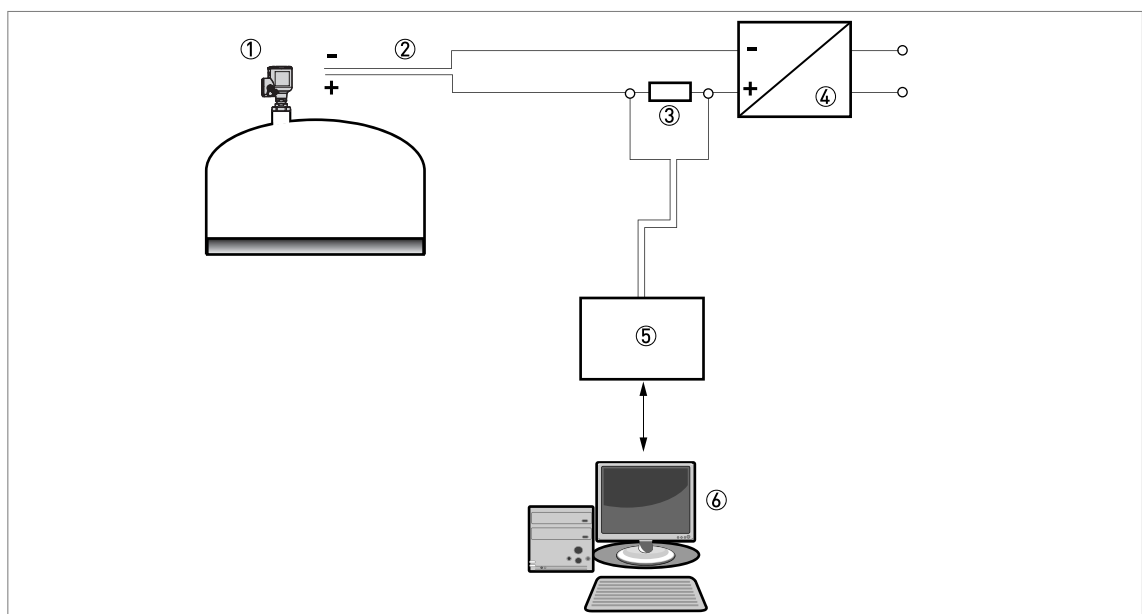

Figure 4-8: Point-to-point connection (non-Ex)

- ① Address of the device (0 for point-to-point connection)
- ② 4...20 mA + HART®
- ③ Resistor for HART® communication (typically 250 ohms)
- ④ Power supply
- ⑤ HART® converter
- ⑥ HART® communication software

4.7.3 Multi-drop networks

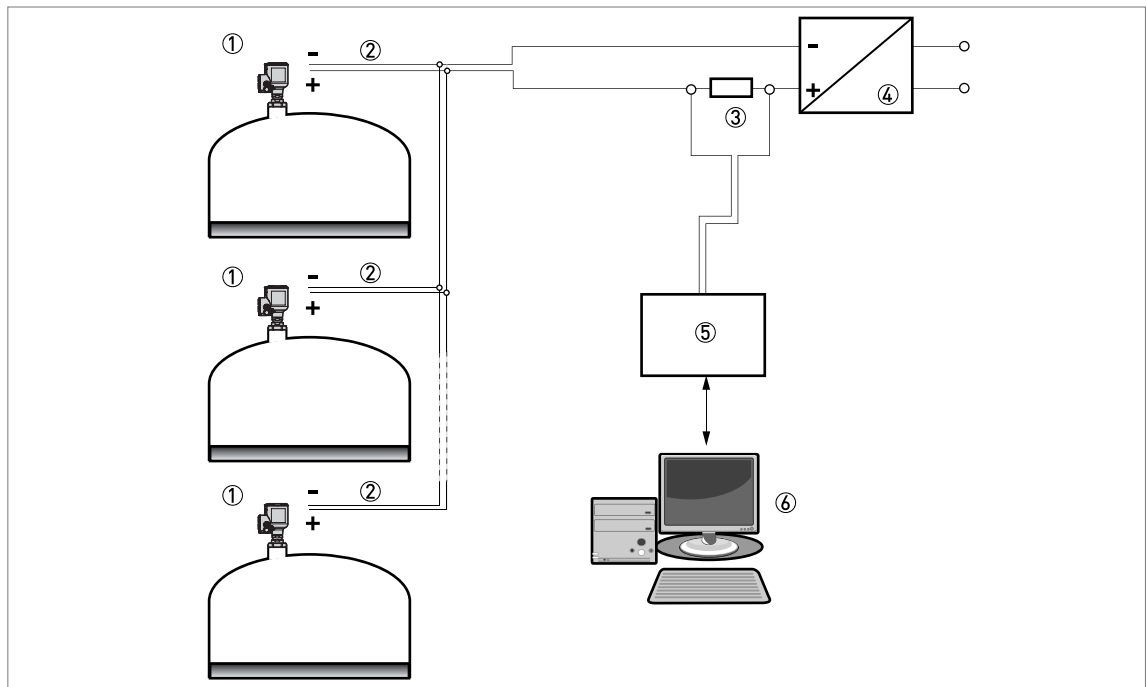

Figure 4-9: Multi-drop network (non-Ex)

- ① Address of the device (each device must have a different address in multidrop networks)
- ② 4 mA + HART®
- ③ Resistor for HART® communication (typically 250 ohms)
- ④ Power supply
- ⑤ HART® converter
- ⑥ HART® communication software

5.1 Start-up checklist

Check these points before you energize the device:

- Are all the wetted components (antenna, flange and gaskets) chemically resistant to the product in the tank?
- Does the information on the signal converter nameplate agree with the operating data?
- Did you correctly install the device on the tank?
- Do the electrical connections agree with the national electrical codes? Use the applicable electrical cables with the cable glands.



DANGER!

Before you energize the device, make sure that the supply voltage and polarity are correct.



DANGER!

If the device has a Hazardous Locations approval, make sure that the device and the installation agrees with the requirements of the certificate of compliance.

5.2 How to start the device



- Connect the converter to the power supply.
- Energize the converter.

➔ **Devices with the LCD display option only:** After 10 seconds the screen will display "REFLEX RA" and the logo of the supplier. After 40 seconds the default screen will appear. The device will show measurement data. Measurements agree with specifications given in the customer order.



CAUTION!

*If the manufacturer received data about the installation, the device will display readings correctly. If not, go to sub-menu **A.4 Application Assistant** in the configuration menu to select the correct settings.*

5.3 Operating concept

You can read measurements and configure the device with:

- A digital display screen (optional).
- A connection to a system or PC with PACTware™. You can download the Device Type Manager (DTM) file from the website.
- A connection to a system or PC with AMS™. You can download the Device Description (DD) file from the website.
- A connection to a HART® Field Communicator. You can download the Device Description (DD) file from the website.

5.4 Digital display screen

If you remove the housing cover, you can push the buttons on the keypad. If you cannot remove the housing cover, you can operate the keypad with a bar magnet. For more data, refer to *Keypad buttons* on page 49.

5.4.1 Display screen layout

Display in Normal mode

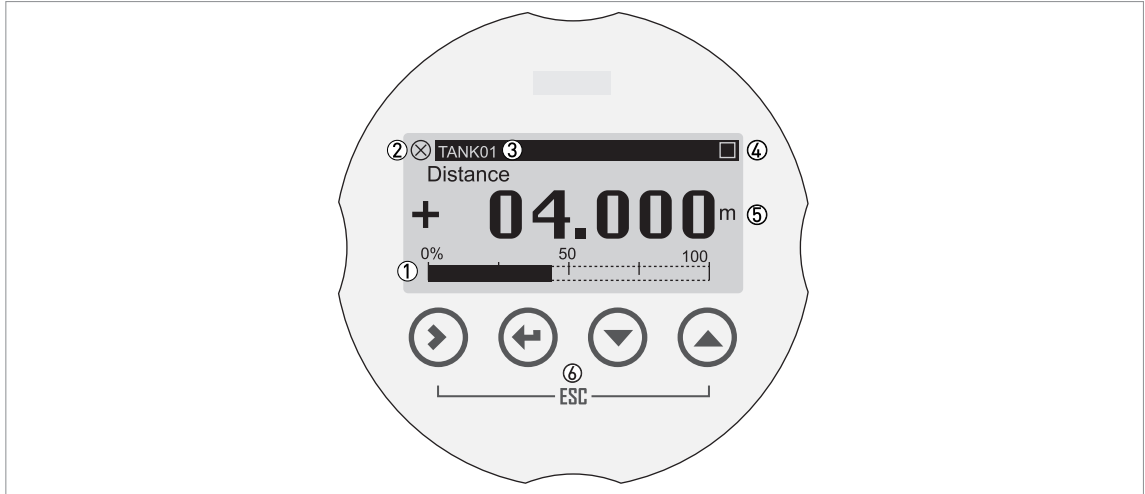

Figure 5-1: Display screen layout in Normal mode (measurement data)

- ① Current output percentage (bar graph)
- ② Device status (NAMUR NE 107 symbols)
- ③ Device tag name
- ④ Keypad operation indicator (shown when you push a button or operate the keypad with a bar magnet)
- ⑤ Measurement value and units
- ⑥ Keypad buttons with Hall effect sensors (sensors sensitive to large changes in magnetic field strength)

The output percentage bar graph is only shown if you set "One Value and Bar" or "Two Values and Bar" in menu items C6.4.1 **Function** (1st Meas. page) or C6.5.1 **Function** (2nd Meas. Page). If menu item C6.4.2 1st Value Variable (1st Meas. page) is set to "Level", then the device shows "Level" as the current output percentage in Normal mode (refer to item ① in the illustration).

Display in Program mode



Figure 5-2: Display screen layout in Program mode

- ① Menu number or menu item number
- ② Location (menu) of sub-menu or menu item
- ③ Menu item name

5.4.2 Keypad buttons

Functions of keypad buttons

Keypad button	Symbol	Function
[Right]	[>]	<p>Normal mode: Enter Program mode</p> <p>Program mode:</p> <p>Menu: Enter the sub-menu or menu item</p> <p>Menu item: Move cursor one digit to the right (this includes the decimal point). If the cursor is on the last digit, a push of this button will move the cursor to the first digit.</p>
[Return]	[↵]	<p>Normal mode: None</p> <p>Program mode:</p> <p>Menu: Exit the menu. If you are in the top level menu, the device goes back to Normal mode.</p> <p>Menu item: Confirm change and exit the menu item.</p>
[Escape]	[>]+[▲]	<p>Normal mode: None</p> <p>Program mode:</p> <p>Menu: Exit the menu.</p> <p>Menu item: Exit the menu item. This step also cancels the change made to the setting in the menu item.</p>
[Down]	[▼]	<p>Normal mode: Change screen (measurement pages 1 and 2 and the status message page)</p> <p>Program mode: Decrease value or change parameter</p>
[Up]	[▲]	<p>Normal mode: Change screen (measurement pages 1 and 2 and the status message page)</p> <p>Program mode: Increase value or change parameter</p>

For more data on keypad functions, refer to *Keypad functions* on page 60.

How to push the keypad buttons with your hand

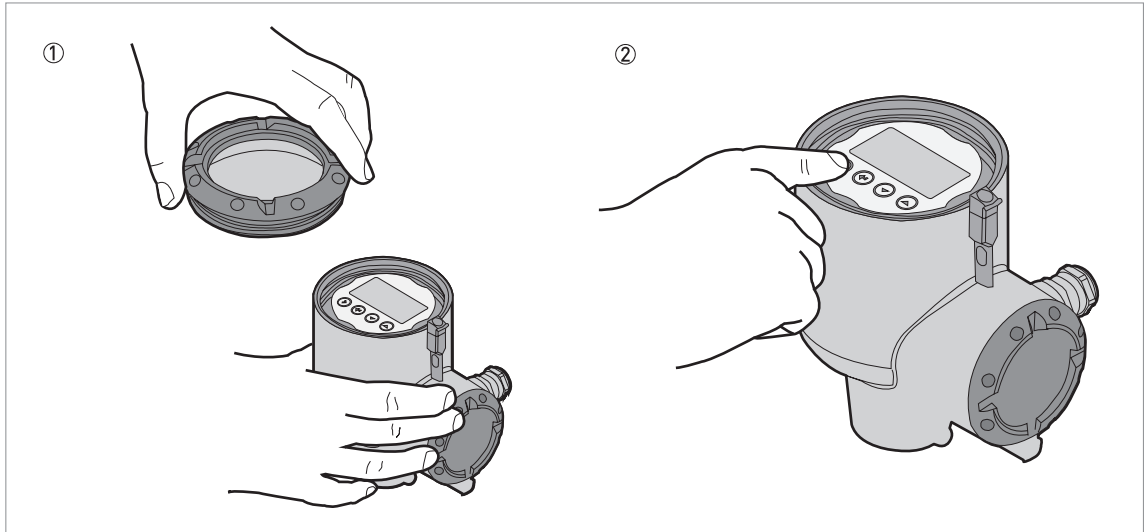

Figure 5-3: How to push the keypad buttons with your hand

Equipment needed

- Cover wrench



- ① Remove the housing cover with the cover wrench supplied with the device.
- ② Push the buttons on the keypad.
- ➡ This will operate the device.

How to operate the keypad buttons with a bar magnet

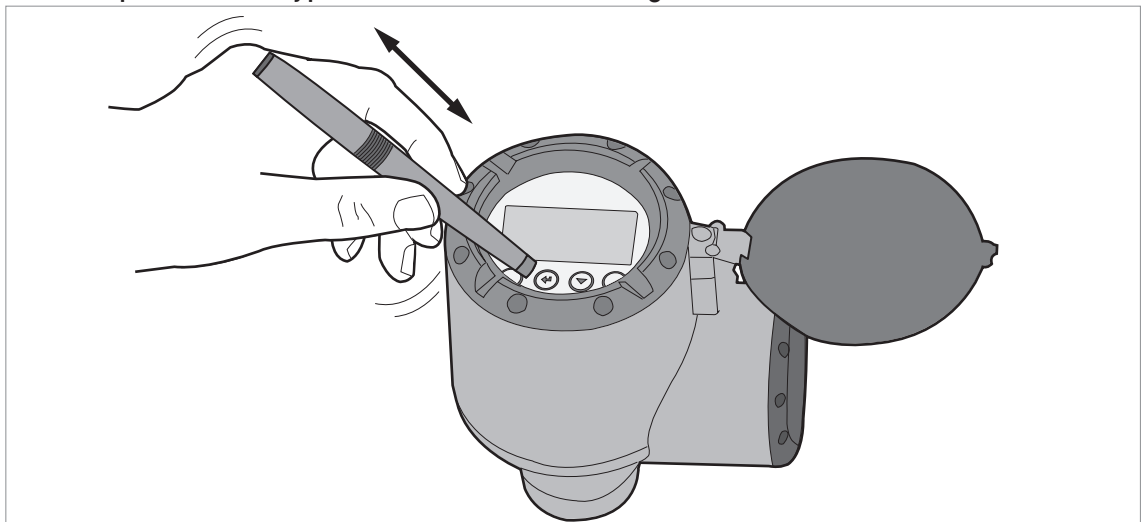

Figure 5-4: How to operate the keypad buttons with a bar magnet

Equipment needed

- Bar magnet

**INFORMATION!**

It is not necessary to remove the display housing cover to do this procedure.



- Hold the bar magnet near to a keypad button.
- The keypad button will operate. If you must operate the button more than one time, remove the bar magnet and then hold it near to the button again.

5.5 Remote communication with PACTware™

PACTware™ displays measurement information clearly and lets you configure the device from a remote location. It is an Open Source, open configuration software for all field devices. It uses Field Device Tool (FDT) technology. FDT is a communication standard for sending information between the system and the field device. This standard agrees with IEC 62453. Field devices are easily integrated. Installation is supported by a user-friendly Wizard.

Install these software programs and equipment:

- Microsoft® .NET Framework version 2.0 or later.
- PACTware.
- HART® converter (USB, RS232...).
- The Device Type Manager (DTM) for the device.

You can download the latest version of PACTware™ and the DTM from our website.

Refer also to the PACTware Consortium site at <http://www.pactware.com>.



Figure 5-5: Screen from the PACTware™ user interface

- ① DTM menu
- ② Information for device identification
- ③ Installation parameters menu and menu items

5.6 Remote communication with the AMS™ Device Manager

The AMS™ Device Manager is an industrial Plant Asset Management (PAM) software tool. Its role is to:

- Store configuration information for each device.
- Store and read process data.
- Store and read diagnostic status information.
- Help plan preventive maintenance to reduce a plant's downtime to a minimum.

You can download the DD file from our website.

6.1 User modes

- Normal mode** This mode shows measurement data and status messages. For more data about measurements, refer to *Normal mode* on page 53. For more data about status messages, refer to *Status messages and diagnostic data* on page 103.
- Program mode** Use this mode to read and change parameters, commission the device, create tables for volume or mass measurement, and change critical values to measure in difficult process conditions. To change settings in Program mode, you must use the device with the correct access level (user, operator or expert). For more data about menu items, refer to *Function description* on page 70.
- All users can read the settings in Program mode, but only users with "Operator" and "Expert" access levels can change settings. For more data about access levels, refer to *Protection of the device settings (access levels)* on page 57.

6.2 Normal mode

This mode shows measurement data. Use the display keypad to change the type of measurement data shown on the screen and to read the device status messages.

There are 5 options to show the measurement data on the display screen. Refer to the illustration that follows:

Measurement data options

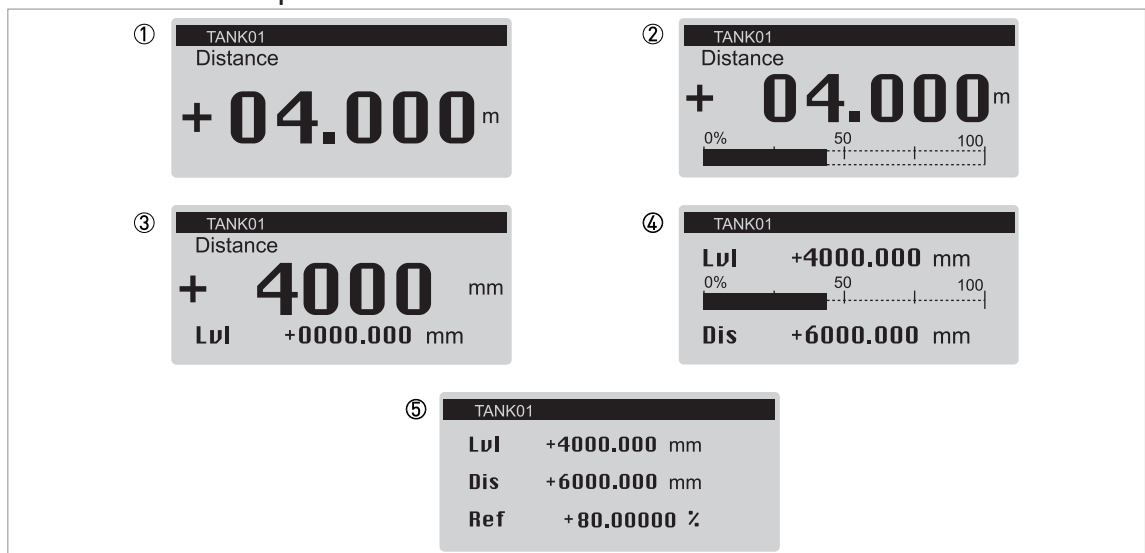

Figure 6-1: Measurement data options in Normal mode

- ① One value
- ② One value and % bar graph of the scale for the measurement value
- ③ Two values
- ④ Two values and % bar graph of the scale for the top measurement value
- ⑤ Three values

**INFORMATION!****Current output and LCD display settings**

When you do the **Standard setup** procedure, the measurement value on the first measurement page of the LCD display (in Normal mode) automatically uses settings with the same parameters and values as the current output settings (measurement variable, 0% range and 100% range). The first measurement page shows "one value and bar" by default. If you must show one or more measurement values that are different to the transmitted output signal, change the settings in the C6.4 1st Meas. Page and C6.5 2nd Meas. Page menus. For more data, refer to Function description on page 70 – table C. Full Setup menu (C6 Display).

Measurement data includes different measurement types (level, distance, volume, ullage volume, mass etc.). Some measurement types will only be available in Normal mode if you entered the correct parameters in Program mode. Normal mode shows abbreviations of measurement types if the measurement page is configured to show more than one measurement value. For a list of the abbreviations used in Normal mode, refer to the table that follows:

Abbreviations of measurement types used in Normal mode

Measurement type	Abbreviation
Distance	Dis
Level	Lvl
Reflection	Ref
Sensor value	SV
Volume	Vol
Ullage volume	Ull
Mass	M
Ullage mass	UllM
Linearized distance	Ldis or Distance Lin.
Linearized level	LLvl or Level Lin.

Measurement data format errors



Figure 6-2: Error symbol: the number of digits and decimal places is not sufficient for the measurement data

- ① Error symbol: the number of digits and decimal places is not sufficient for the measurement data. It is possible that the length units must be changed from "mm" to "m".

In this example, the device measures a distance of 10.001 m, but C7.5.1 Length is set to "mm" and C6.4.5 Format 1st Value is set to "X.XXX" (four digits with three decimal places). This is not sufficient to show a measurement value of 10.001 m. If the measurement value is equal to or more than 10 m, set C6.4.5 Format 1st Value to "Automatic".

You can change the number of digits and decimal places in the measurement values shown in Normal mode.



INFORMATION!

How to change the number of digits and decimal places in the measurement values shown in Normal mode

1st Measurement Page: Go to menu C6.4 1st Measur. Page and then change the number of digits and decimal places in C6.4.5 Format 1st value, C6.4.7 Format 2nd value or C6.4.9 Format 3rd value.

2nd Measurement Page: Go to menu C6.5 2nd Measur. Page and then change the number of digits and decimal places in C6.5.5 Format 1st value, C6.5.7 Format 2nd value or C6.5.9 Format 3rd value.

If there is a large change in a measurement value, set the related menu item to "Automatic".

Volume or mass measurement

You must make a conversion table (strapping table) to show measurement data as a volume or a mass. Go to C3.2 Input table (**Full Setup > Conversion**) to make the strapping table. For more data, refer to *How to configure the device to measure volume or mass* on page 99.

Functions of keypad buttons (Normal mode)

Keypad button	Symbol	Function
[Right]	[>]	Enter Program mode
[Return]	[←]	—
[Escape]	[>]+[▲]	—
[Down]	[▼]	Change screen (measurement pages 1 and 2, and the status message page)
[Up]	[▲]	Change screen (measurement pages 1 and 2 and the status message page)

Measurement type definitions

Measurement type	Description	Available units
Level	This is a display and an output function option. It is the height from the bottom of the tank to the surface of the liquid (Tank height - Distance). If menu item C1.11 Tank Bottom Offset in Program mode is not zero, then this value will be (Tank Height + Tank Bottom Offset) - Sensor value.	m, cm, mm, in (inches), ft (feet), custom length unit
Distance	This is a display and an output function option. It is the distance from the face of the process connection (flange face or thread stop) to the surface of the liquid. If menu item C1.10 Reference Offset in Program mode is not zero, then this value will be Sensor value + Reference Offset. If menu item C1.10 Reference Offset is zero (0), then Distance = Sensor value. Refer also to "Sensor value" in this table.	m, cm, mm, in (inches), ft (feet), custom length unit
Volume	This is a display and an output function option. It gives the volume or mass of the tank contents. This data is available if you prepare a volume table in Program mode (Full Setup > Conversion). For data on how to prepare the conversion table, refer to <i>How to configure the device to measure volume or mass</i> on page 99.	m ³ , L, hL (hectolitre), in ³ , ft ³ , gal (US gallons), ImpGal (Imperial gallons), yd ³ , bbl (oil), bbl (beer), custom volume unit
Ullage volume	This is a display and an output function option. It gives the empty volume that can be put in the tank. This data is available if you prepare a volume table in Program mode (Full Setup > Conversion). For data on how to prepare the conversion table, refer to <i>How to configure the device to measure volume or mass</i> on page 99.	m ³ , L, hL (hectolitre), in ³ , ft ³ , gal (US gallons), ImpGal (Imperial gallons), yd ³ , bbl (oil), bbl (beer), custom volume unit
Mass	This is a display and an output function option. It gives the mass of the tank contents. This data is available if you prepare a volume or mass table in Program mode (Full Setup > Conversion). For data on how to prepare the conversion table, refer to <i>How to configure the device to measure volume or mass</i> on page 99.	kg, tn.l. (long ton), tn.sh. (short ton), lb, t (tonne), Cst. Mass (custom mass unit)
Ullage mass	This is a display and an output function option. It gives the remaining mass that can be put in the tank. This data is available if you prepare a volume or mass table in Program mode (Full Setup > Conversion). For data on how to prepare the conversion table, refer to <i>How to configure the device to measure volume or mass</i> on page 99.	kg, tn.l. (long ton), tn.sh. (short ton), lb, t (tonne), Cst. Mass (custom mass unit)
Reflection	This is a display and an output function option. It is the percentage of the emitted radar signal which makes a reflection on the surface of the liquid and is received by the device. If the distance measured is less than 1 metre, then the reflection value is 0%.	%
Sensor value	This is a display and an output function option. It is the distance from the face of the process connection (flange face or thread stop) to the surface of the liquid. You cannot change this value in Program mode. Refer also to "Distance" in this table.	m, cm, mm, in (inches), ft (feet), custom length unit

6.3 Program mode

6.3.1 General notes

Change the settings of your device in **Program Mode**. Data about the menus is given on page 70. You can:

- Use the **A Quick Setup** menu to change the display language, change the tag name, log in to change settings, do standard setup and empty spectrum recording procedures.
- Use the **B Test** menu to run diagnostic tests, read measurement and spectrum data.
- Use the **C Full Setup** menu to change settings. You can set up a conversion table for volume or mass measurement, change current output values, change HART® settings, change how the measurement data is shown in Normal mode, read device identification data, change critical parameters for difficult process conditions, change the password, change measurement units or reset the device to factory default settings.



CAUTION!

If you did not supply all installation data to the supplier before the delivery, the standard setup procedure in the Quick Setup menu is mandatory.



INFORMATION!

*It is not possible to enter the **D Service** menu. This menu is for factory calibration and approved personnel only.*

6.3.2 Protection of the device settings (access levels)

The settings of this device have three different access levels: "User", "Operator" and "Expert". "Expert" is the highest access level. The highest access level lets you change all available functions.

Access levels and applicable functions in Program mode

Access level	Default password	Applicable functions in Program mode (overview)
Expert	0058	<ul style="list-style-type: none"> • Read: Measurement data and error messages available at the "User" access level (Normal mode and menu items B2 Actual Values and C7.3.1 Message View) • Change: All sub-menus in menus A Quick Setup, B Test and C Full Setup <p>NOTE: You can change the password for the "Expert" access level in menu item C7.2.2 Change Password. Refer to the INFORMATION! note that follows.</p>

Operator	0009	<ul style="list-style-type: none"> Read: Measurement data and error messages available at the "User" access level (Normal mode and menu items B2 Actual Values and C7.3.1 Message View) Change: All HART® settings (C5) – but not C5.1.1 Current Loop Mode <p>NOTE: You can change the password for the "Operator" access level in menu item C7.2.2 Change Password. Refer to the INFORMATION! note that follows.</p>
User	—	<ul style="list-style-type: none"> Read: Measurement data and error messages (Normal mode and menu items B2 Actual Values and C7.3.1 Message View) Read: All settings in menus A Quick Setup, B Test and C Full Setup Change: All settings in menu C6 Display (language, backlight on/off, screen contrast and measurement data display options (Normal mode, pages 1 and 2)) and C7.5 Units (length, volume, mass and custom units) Change: Access level. Go to menu item A3 Login or C7.2.1 Login to change from "User" to "Operator" or "Expert" access levels

If your access level is too low, the display will show a "lock" symbol adjacent to menu items in Program mode. If it is necessary to change a setting, move the cursor to the menu item, push [➤] and enter the password used at this time for that menu item.



Figure 6-3: Lock symbol

① Lock symbol. If the display shows this symbol, you cannot change the setting.



How to change the password

- Push [➤] to enter Program mode.
- Push 2 × [▼], [➤], 5 × [▼], [➤], [▼] and [➤] to go to the menu C7.2 Security.
- Push [➤] to enter menu item C7.2.1 Login.
- Enter the password used at this time for a given access level ("Operator" or "Expert"). If it is the default password, refer to the value given in the "Access levels and applicable functions in Program mode" table in this section.
- Push [←] and [▼] to go to the menu item C7.2.2 Change Password.
- Push [➤] to enter the menu item.
- Enter the password used at this time for the access level set at the start of this procedure. If it is the default password, refer to the value given in the "Access levels and applicable functions in Program mode" table in this section.
- Enter the new password.
- ➡ If you change the password for the "Operator" access level, then the first three digits must be zero (000x). The last digit can be a number (1...9) or a letter (A...F). If you change the password for the "Expert" access level, then the first two digits must be zero (00xx). The last two digits can be a number (1...9) or a letter (A...F).
- Enter the new password again.
- Push 6 × [←] to go back to Normal mode.

- End of the procedure.

**INFORMATION!**

Each access level has a four-digit hexadecimal password.

The first three digits of the password for the "Operator" access level must be zero (000x). The last digit can be a number (1...9) or a letter (A...F).

The first two digits of the password for the "Expert" access level must be zero (00xx). The last two digits can be a number (1...9) or a letter (A...F).

**INFORMATION!**

Make a note of the password and keep it in a safe place. If you lose the password, please speak or write to your supplier.

**INFORMATION!**

If you de-energize the device and then energize it again, the access level will go back to "User". If you do not touch the keypad for 5 minutes, the device goes back to Normal mode and the access level will go back to "User".

6.3.3 How to get access to the Quick Setup menu

The Quick Setup menu contains the menu items that are necessary for most configurations of the device. The menu items are divided into 2 groups: "Standard Setup" and "Empty Spectrum". The "Standard Setup" group lets the user (with "Expert" access level) set the tank height, tank type (process, storage etc.), output variable, output current range, 0% range, 100% range, error function and error delay. "Empty Spectrum" is a procedure that finds interference signals in the tank and uses a filter to remove them from the measurement data.

**CAUTION!**

If you did not supply all installation data to the supplier before the delivery, the standard setup procedure in the Quick Setup menu is mandatory.

**Do the steps that follow:**

- Push [➤] to enter Program mode.
- Push [➤], 2 × [▼] to go to the menu item A3 Login.
- Push [➤]. Enter the password used at this time for the "Expert" access level. If it is the default password, enter "0058".
- Push [←], [▼] and [➤] to go to the menu item A4.1 Standard Setup.
- Push [➤]. Do the basic configuration of the device in the "Standard Setup" menu. For more data on the procedure, refer to *Standard setup* on page 88. Push [←] at the end of each step of the procedure to continue to the next step.
- Push [▼] and [➤] to go to the menu item A4.2.1 Record Spectrum.
- Push [➤] to start the empty spectrum recording procedure. For more data, refer to *Empty spectrum recording* on page 92. Push [←] at the end of each step of the procedure to continue to the next step.
- End of the procedure.

6.3.4 Keypad functions

Menu navigation



Figure 6-4: Menu navigation

- ① Menu number or menu item number
- ② Location (menu) of sub-menu or menu item
- ③ Menu item name

This is what you see when you are in Program mode. The functions of the buttons are given in the table that follows:

Functions of buttons for menu navigation

Button	Description	Function
	Right	<ul style="list-style-type: none"> • Go down a menu level (for example, from menu C1 to sub-menu C1.1). • Enter the menu item.
	Enter	<ul style="list-style-type: none"> • Go up a menu level (for example, from sub-menu C1.1 to menu C1). • Go to Normal mode. If you changed settings in Program mode, you must save or cancel your new settings. For more data, refer to <i>How to save settings changed in Program mode</i> on page 63.
	Esc (Escape)	<ul style="list-style-type: none"> • Go up a menu level (for example, from sub-menu C1.1 to menu C1).
	Down	<ul style="list-style-type: none"> • Scroll down the menu list (for example, from menu C1 to menu C2). • Scroll down the sub-menu list (for example, from sub-menu C2.1 to sub-menu C2.2).
	Up	<ul style="list-style-type: none"> • Scroll up the menu list (for example, from menu C2 to menu C1). • Scroll up the sub-menu list (for example, from sub-menu C2.2 to sub-menu C2.1).

Lists of parameters in menu items

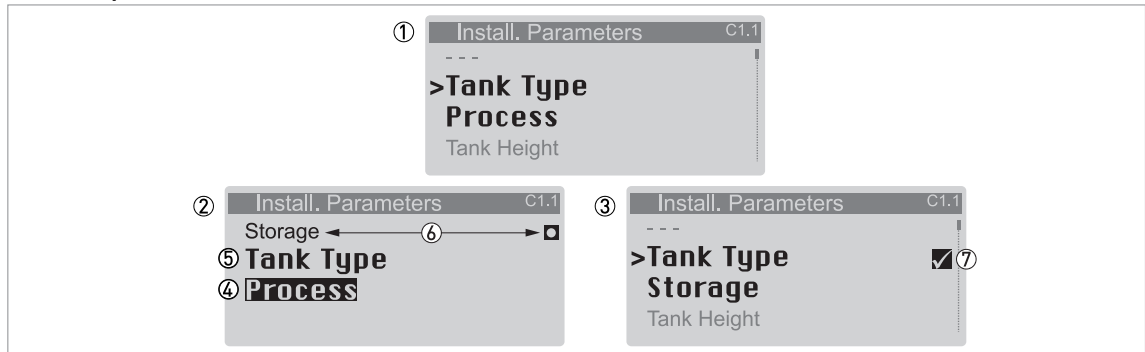

Figure 6-5: Lists of parameters in menu items

- ① Menu item with parameter stored at this time (first screen). Push [>] to enter the menu item.
- ② Push [▲] or [▼] to change the parameter
- ③ Push [←] to set the new parameter and go back to the menu level
- ④ Parameter
- ⑤ Menu item name
- ⑥ The factory default value (left side) and factory default symbol (right side)
- ⑦ A "tick" symbol shows that there is a new setting (the new setting is not saved at this time)

This is what you see when you select a menu item that has a list of parameters. The functions of the buttons are given in the table that follows:

Function of buttons in menu items that have a list of parameters

Button	Description	Function
	Right	—
	Enter	Select the parameter and go back to the menu
	Esc (Escape)	If you push these buttons immediately after you change a parameter, the device also ignores this change and goes back to the menu.
	Down	Scroll down the list
	Up	Scroll up the list

Values in menu items

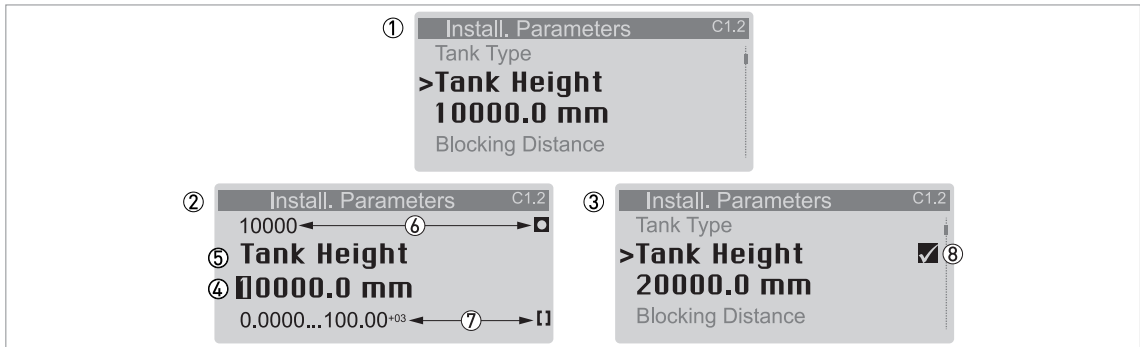

Figure 6-6: Values in menu items

- ① Menu item with values stored at this time (first screen). Push [➤] to enter the menu item. A cursor shows on the first digit.
- ② Push [➤] again and again to move the cursor. Push [▲] or [▼] to change the value of the digit. If the digit is part of a number, then make a selection from 0...9. If the digit is part of a custom unit name, then refer to the tables at the end of this section for a list of the available characters. If the cursor is on the decimal point, you can change the position of the decimal point.
- ③ Push [↶] to set the new parameter and go back to the menu level
- ④ Make a selection: put the cursor on a digit or the decimal point.
- ⑤ Menu item name
- ⑥ The factory default value (left side) and factory default symbol (right side)
- ⑦ The minimum and maximum values [min./max.] for this menu item (left side) and min./max. symbol (right side)
- ⑧ A "tick" symbol shows that there is a new setting (the new setting is not saved at this time)

This is what you see when you select a menu item that has a value.



INFORMATION!

If menu items have values that you can change, very large and very small values can be written as a value with an exponent (b^n). For example, if the value shown on the display is 100.00^{+03} , this value is equal to 100×10^3 or 100000.

The functions of the buttons are given in the table that follows:

Function of buttons in menu items that have values

Button	Description	Function
	Right	<ul style="list-style-type: none"> Enter the menu item and see the value stored at this time. Enter the menu item configuration level to change the value. Move the cursor to the next digit on the right. If the cursor is on the last digit, push [➤] again to go back to the first digit. You can also put the cursor on the decimal point.
	Enter	Accept the value and go back to the sub-menu.
	Esc (Escape)	If you push these buttons immediately after you change a value, the device also ignores this change and goes back to the menu.
	Down	If the cursor is on a number, this button decreases the digit value. If the cursor is on the decimal point, this button moves the decimal point to the left (this decreases the value by a factor of 10).
	Up	If the cursor is on a number, this button increases the digit value. If the cursor is on the decimal point, this button moves the decimal point to the right (this increases the value by a factor of 10).

**INFORMATION!****Values in menu items**

If the digit is part of a custom unit name, then refer to the list of available characters that follows:

Numbers

0	1	2	3	4	5	6	7	8	9
---	---	---	---	---	---	---	---	---	---

Lower case letters

a	b	c	d	e	f	g	h	i	j
k	l	m	n	o	p	q	r	s	t
u	v	w	x	y	z				

Upper case letters

A	B	C	D	E	F	G	H	I	J
K	L	M	N	O	P	Q	R	S	T
U	V	W	X	Y	Z				

Special characters

2	3	_	-	/	.				
---	---	---	---	---	---	--	--	--	--

6.3.5 How to save settings changed in Program mode



- When you have changed parameters in all the necessary menu items, push [←] to accept the new parameter.
- Push [←] again and again to go back to the "Save Configuration?" screen.
- The device will ask you to save or cancel your settings. Push [▲] or [▼] to make a selection from **Yes**, **No** or **Back**. **Back** makes the display go back to Program mode. If this screen is set to "Yes" or "No", push [←] to accept (Yes) or reject (No) the new settings.
- ➡ If you push [←] when the screen is set to "Yes" or "No", the display goes back to Normal mode.

6.3.6 Menu overview

Menu overview: A – Quick Setup

Normal	Program					
	Menu A		Submenus			
> ←	↓ ↑	> ←	↓ ↑	> ←	↓ ↑	> ←
	A Quick Setup		A1 Language			
			A2Tag			
			A3 Login			
			A4 Application Assistant		A4.1 Standard Setup	A4.1.1.1 Length Unit
						A4.1.2.1 Tank Type
						A4.1.2.2 Tank Height
						A4.1.3.1 Current Out. 1 Var.
						A4.1.3.2 0% Range
						A4.1.3.3 100% Range
						A4.1.3.4 Current Out. Range
					A4.1.3.5 Error Function	
				A4.2 Empty Spectrum / A4.2.1 Record Spectrum	A4.2.1.2 Empty Spectrum Type	
					A4.2.1.3 Partial Distance ①	
					A4.2.1.4 Check Tank Internals and Contents	
					A4.2.1.5 Start Recording?	
					A4.2.1.6 Recording Empty Spectrum Data	
					A4.2.1.10 Empty Spectrum Graph	
					A4.2.1.11 Save Spectrum?	
					A4.2.1.12 Empty Spectrum Enable	

① The device shows this menu item if you set the menu item A4.2.1.1 to "Partial, Average" or "Partial, Max"

Menu overview: B – Test

Normal	Program					
	Menu B		Submenus			
> ←	↓ ↑	> ←	↓ ↑	> ←	↓ ↑	> ← ↓ ↑ >
	B Test		B1 Simulation ①		B1.1 Set Value	B1.1.2 Level
						B1.1.3 Distance
						B1.1.4 Reflection
						B1.1.5 Level Lin. ②
						B1.1.6 Volume ②
						B1.1.7 Mass ②
						B1.1.8 Distance Lin. ②
						B1.1.9 Ullage Volume ②
						B1.1.10 Ullage Mass ②
						B1.2 Output
				B2 Actual Values	B2.1 Operating Time	
					B2.3 Sensor Value	
					B2.4 Level	
					B2.5 Distance	
					B2.6 Reflection	
					B2.7 Level Lin. ②	
					B2.8 Volume ②	
					B2.9 Mass ②	
					B2.10 Distance Lin. ②	
					B2.11 Ullage Volume ②	
			B2.12 Ullage Mass ②			
			B2.13 Sensor Temp.			
			B2.14 Converter Temp.			
			B3 Power Spectrum		B3.2 Power Spectrum	
			B4 Corrected Spectrum	B4.2 Corrected Spectrum		
			B5 Empty Spectrum	B5.2 Empty Spectrum		

① You must enter the "Expert" password in A3 Login or C7.2.1 Login to find and use this menu

② The device shows this menu item if you make a strapping table in menu C.3 Conversion

Menu overview: C – Full Setup

Normal	Program								
	Menu C		Submenus						
> ←	↓ ↑	> ←	↓ ↑	> ←	↓ ↑	> ← ↓ ↑ >			
	C Full Setup	C1 Install. Parameters			C1.1 Tank Type				
					C1.2 Tank Height				
					C1.5 Blocking Distance				
					C1.6 Time Constant				
					C1.7 Antenna Type				
					C1.8 Antenna Extension				
					C1.9 Distance Piece				
					C1.10 Reference Offset				
					C1.11 Tank Bottom Offset				
				C2 Process				C2.1 Tracking Velocity	
								C2.2 Epsilon R Product	
						C2.3 Epsilon R Gas			
						C2.4 Measuring Mode			
						C2.5 Overfill Detection			
						C2.6 Overfill Threshold ①			
						C2.7 Mult. Refl. Enable			
			C3 Conversion ②			C3.1 Edit Table			
								C3.1.1 Erase Table? ③	
								C3.1.3 Select Conversion? ④	
					C3.2 Input Table	C3.2.2 Point			
					C3.2.4 Level				
					C3.2.5 Conv. Value				
	C Full Setup	C4 Output			C4.1 Current Output 1				
							C4.1.1 Current Out. 1 Var.		
							C4.1.2 0% Range		
							C4.1.3 100% Range		
							C4.1.4 Current Out. Range		
							C4.1.5 Error Function		
							C4.1.7 Low Error Current ⑤		
							C4.1.8 High Error Current ⑤		
				C4.1.9.2 Trimming / 4mA Trimming					
				C4.1.9.5 Trimming / 20mA Trimming					

Normal	Program						
	Menu C		Submenus				
> ←	↓ ↑	> ←	↓ ↑	> ←	↓ ↑	> ← ↓ ↑ >	
	C Full Setup		C5 Communication	C5.1 HART		C5.1.1 Current Loop Mode	
							C5.1.2.1 Identification / Polling Address
							C5.1.2.2 Identification / Tag
							C5.1.2.3 Identification / Long Tag
							C5.1.2.4 Identification / Manufacturer ID
							C5.1.2.5 Identification / Device Type
							C5.1.2.6 Identification / Device ID
							C5.1.2.7 Identification / Universal Revision
							C5.1.2.8 Identification / Device Revision
							C5.1.2.9 Identification / Software Revision
							C5.1.2.10 Identification / Hardware Revision
							C5.1.3.1 Device Information / Descriptor
							C5.1.3.2 Device Information / Message
							C5.1.3.3 Device Information / Date
							C5.1.3.4 Device Information / Cfg. Change Counter
							C5.1.4.1 HART Variables / Current Out. 1 Var.
							C5.1.4.2 HART Variables / HART sec./CO2 Var.
							C5.1.4.3 HART Variables / Tertiary Var.
							C5.1.4.4 HART Variables / Quaternary Var.
				C6 Display			C6.1 Language
						C6.2 Backlight	
						C6.3 Contrast	

Normal	Program								
	Menu C		Submenus						
> ⏪	↓ ↑	> ⏪	↓ ↑	> ⏪	↓ ↑	> ⏪	↓ ↑ >		
	C Full Setup		C6 Display		C6.4 1st Meas. page		C6.4.1 Function		
								C6.4.2 1st Value Variable	
								C6.4.3 0% Range	
								C6.4.4 100% Range	
								C6.4.5 Format 1st Value	
								C6.4.6 2nd Value Variable ⑥	
								C6.4.7 Format 2nd Value ⑥	
								C6.4.8 3rd Value Variable ⑥	
								C6.4.9 Format 3rd Value ⑥	
								C6.5 2nd Meas. page	
								C6.5.2 1st Value Variable	
								C6.5.3 0% Range	
								C6.5.4 100% Range	
								C6.5.5 Format 1st Value	
								C6.5.6 2nd Value Variable ⑦	
								C6.5.7 Format 2nd Value ⑦	
								C6.5.8 3rd Value Variable ⑦	
								C6.5.9 Format 3rd Value ⑦	
				C7 Device		C7.1 Information		C7.1.1 Tag	
									C7.1.2 Serial Number
									C7.1.3 Device Name
									C7.1.4 V Number
									C7.1.5 Electronic Revision
									C7.1.6 Software Version
									C7.1.7 Electronic Serial No.
									C7.1.8 Production Date
									C7.1.9 Calibration Date
						C7.2 Security		C7.2.1 Login	
									C7.2.2 Change Password
									C7.2.3 Reset Passwords
							C7.2.4 Unlock Extended Range ⑧		
							C7.2.5 Unlock SIL ⑧		
					C7.3 Errors		C7.3.1 Message View		
								C7.3.2.1 Error-Mapping / Sensor: Information	

Normal	Program						
	Menu C		Submenus				
> ←	↓ ↑	> ←	↓ ↑	> ←	↓ ↑	> ←	↓ ↑ >
	C Full Setup		C7 Device		C7.5 Units		C7.5.1 Length
							C7.5.2.1 Cst. Length / Text
							C7.5.2.2 Cst. Length / Offset
							C7.5.2.3 Cst. Length / Factor
							C7.5.3 Volume
							C7.5.4.1 Cst. Volume / Text
							C7.5.4.2 Cst. Volume / Offset
							C7.5.4.1 Cst. Volume / Factor
							C7.5.5 Mass
							C7.5.6.1 Cst. Mass / Text
							C7.5.6.2 Cst. Mass / Offset
							C7.5.6.3 Cst. Mass / Factor
					C7.6 Factory Default		C7.6.1 Reset to Fact. Def.? ②

- ① The device shows this menu item if you set the menu item C2.5 to "Enabled"
- ② You must enter the "Expert" password in A3 Login or C7.2.1 Login to find and use this menu
- ③ This menu item is available if the device has a strapping table
- ④ This menu item is available if the device does not have a strapping table
- ⑤ Menu item C4.1.7 is available if you set menu item C4.15 to "Low". Menu item C4.1.8 is available if you set menu item C4.15 to "High".
- ⑥ This menu item is available if the correct parameter is set in C6.4.1 Function. For more data, refer to table C. Full Setup menu (C6.4 1st Meas. Page) in the section that follows.
- ⑦ This menu item is available if the correct parameter is set in C6.5.1 Function. For more data, refer to table C. Full Setup menu (C6.5 2nd Meas. Page) in the section that follows.
- ⑧ This menu item can only be unlocked at the factory

6.3.7 Function description

A – Quick Setup menu

Menu No.	Function	Function description	Selection list	Default
A1	Language	Make a selection to show the measurement data and settings in one of the languages stored in the device. Minimum access level to change the setting: User	English, French, German, Italian, Japanese, Chinese (simplified), Portuguese, Russian, Spanish, Czech, Polish, Turkish	English
A2	Tag	You can see the TAG name here. The tag name can be a maximum of 8 characters long and it can have numbers, upper-case and lower-case letters and special characters. For more data, refer to <i>Keypad functions</i> on page 60 (values in menu items). Minimum access level to change the setting: Operator	Refer to "Function description"	TANK01
A3	Login	Enter the appropriate password here to change settings. If you do not enter the password, you can only change settings for the "user" access level. For more data, refer to <i>Protection of the device settings (access levels)</i> on page 57.	4-digit hexadecimal password	Refer to "Function description"
A4 Application Assistant				
A4.1	Standard Setup	This starts a quick set-up procedure applicable to most applications. You can set the length unit, installation specifications (tank type, tank height etc.) and current output specifications (0% range, 100% range, error function etc.). For more data about the functions, refer to Table C – Full Setup, in this section. For more data about the procedure, refer to <i>Standard setup</i> on page 88. Minimum access level to do the procedure: Expert		
A4.2	Empty Spectrum	Fixed and moving objects in the tank cause interference signals. Put them through this filter to correctly measure the tank contents. This menu item starts a quick set-up procedure. We recommend that the tank is empty or only filled to the minimum level before you do the procedure. We also recommend that if you installed the device on a tank that has equipment with parts that move (e.g. agitators), start the equipment. Set the Save Spectrum? step to "Yes", Empty Spectrum Enable step to "Enable" at the end the procedure and set the Save Configuration? screen to "Yes" to use the data. For more data about the procedure, refer to <i>Empty spectrum recording</i> on page 92. Refer also to "How to make a filter to remove radar signal interference" on page 102. Minimum access level to do the procedure: Expert		

B – Test menu

Menu No.	Function	Function description	Selection list	Default
----------	----------	----------------------	----------------	---------

B1 Simulation

B1.1 Set Value				
B1.1.2	Level	<p>This sets the device to a given test level value. Make sure that menu item C4.1.1 Current Out. 1 Var. is set to "Level" before the device simulates a level value. This procedure sends an output signal that agrees with the test reading. Output will change to the selected value, independent of the measurement data.</p> <p>When you push [←] to confirm the value, the display shows the question "Start Simulation?" Push [▼] or [▲] to set the display to "Yes". Push [←] again to start the test. The device goes to back to Normal mode after 1 hour.</p> <p>Minimum access level to do the procedure: Expert</p>	min-max: -4900.0...+5100.0 m / -192.91 ⁺⁰³ ...+200.79 ⁺⁰³ in / -16076...+16732 ft	①
B1.1.3	Distance	<p>This sets the device to a given test distance value. Make sure that menu item C4.1.1 Current Out. 1 Var. is set to "Distance" before the device simulates a distance value. This procedure sends an output signal that agrees with the test reading. Output will change to the selected value, independent of the measurement data.</p> <p>When you push [←] to confirm the value, the display shows the question "Start Simulation?" Push [▼] or [▲] to set the display to "Yes". Push [←] again to start the test. The device goes to back to Normal mode after 1 hour.</p> <p>Minimum access level to do the procedure: Expert</p>	min-max: -4900.0...+5100.0 m / -192.91 ⁺⁰³ ...+200.79 ⁺⁰³ in / -16076...+16732 ft	①
B1.1.4	Reflection	<p>This sets the device to a given test reflection value. Make sure that menu item C4.1.1 Current Out. 1 Var. is set to "Reflection" before the device simulates a level value. This procedure sends an output signal that agrees with the test reading. Output will change to the selected value, independent of the measurement data.</p> <p>When you push [←] to confirm the value, the display shows the question "Start Simulation?" Push [▼] or [▲] to set the display to "Yes". Push [←] again to start the test. The device goes to back to Normal mode after 1 hour.</p> <p>Minimum access level to do the procedure: Expert</p>	min-max: 0...100%	①

Menu No.	Function	Function description	Selection list	Default
B1.1.5	Level Lin.	<p>This sets the device to a given test level value (linearized). This menu item is only available if you set up a linearization table in menu item C3.1 Edit Table. Make sure that menu item C4.1.1 Current Out. 1 Var. is set to "Lin. Level" before the device simulates a level value. This procedure sends an output signal that agrees with the test reading. Output will change to the selected value, independent of the measurement data.</p> <p>When you push [↵] to confirm the value, the display shows the question "Start Simulation?" Push [▼] or [▲] to set the display to "Yes". Push [↵] again to start the test. The device goes to back to Normal mode after 1 hour.</p> <p>Minimum access level to do the procedure: Expert</p>	min-max: -5000.0...+5000.0 m / -196.85 ⁺⁰³ ...+196.85 ⁺⁰³ in / -16404...+16404 ft	①
B1.1.6	Volume	<p>This sets the device to a given test volume value. This menu item is only available if you set up a conversion (volume) table in menu item C3.1 Edit Table. Make sure that menu item C4.1.1 Current Out. 1 Var. is set to "Volume" before the device simulates a volume value. This procedure sends an output signal that agrees with the test reading. Output will change to the selected value, independent of the measurement data.</p> <p>When you push [↵] to confirm the value, the display shows the question "Start Simulation?" Push [▼] or [▲] to set the display to "Yes". Push [↵] again to start the test. The device goes to back to Normal mode after 1 hour.</p> <p>Minimum access level to do the procedure: Expert</p>	min-max: 0...1.00 ⁺⁰⁶ m ³	①
B1.1.7	Mass	<p>This sets the device to a given test mass value. This menu item is only available if you set up a conversion (mass) table in menu item C3.1 Edit Table. Make sure that menu item C4.1.1 Current Out. 1 Var. is set to "Mass" before the device simulates a mass value. This procedure sends an output signal that agrees with the test reading. Output will change to the selected value, independent of the measurement data.</p> <p>When you push [↵] to confirm the value, the display shows the question "Start Simulation?" Push [▼] or [▲] to set the display to "Yes". Push [↵] again to start the test. The device goes to back to Normal mode after 1 hour.</p> <p>Minimum access level to do the procedure: Expert</p>	min-max: 0...10.000 ⁺⁰⁹ kg	①

Menu No.	Function	Function description	Selection list	Default
B1.1.8	Distance Lin.	<p>This sets the device to a given test distance value (linearized). This menu item is only available if you set up a linearization table in menu item C3.1 Edit Table. Make sure that menu item C4.1.1 Current Out. 1 Var. is set to "Lin. Distance" before the device simulates a linearized distance value. This procedure sends an output signal that agrees with the test reading. Output will change to the selected value, independent of the measurement data.</p> <p>When you push [←] to confirm the value, the display shows the question "Start Simulation?" Push [▼] or [▲] to set the display to "Yes". Push [←] again to start the test. The device goes to back to Normal mode after 1 hour.</p> <p>Minimum access level to do the procedure: Expert</p>	min-max: -5000.0...+5000.0 m / -196.85 ⁺⁰³ ...+196.85 ⁺⁰³ in / -16404...+16404 ft	①
B1.1.9	Ullage Volume	<p>This sets the device to a given test ullage volume value. This menu item is only available if you set up a conversion (volume) table in menu item C3.1 Edit Table. Make sure that menu item C4.1.1 Current Out. 1 Var. is set to "Ullage Volume" before the device simulates an ullage volume value. This procedure sends an output signal that agrees with the test reading. Output will change to the selected value, independent of the measurement data.</p> <p>When you push [←], the display shows the question "Start Simulation?" Push [▼] or [▲] to set the display to "Yes". Push [←] again to start the test. The device goes to back to Normal mode after 1 hour.</p> <p>Minimum access level to do the procedure: Expert</p>	min-max: 0...1.00 ⁺⁰⁶ m ³	①
B1.1.10	Ullage Mass	<p>This sets the device to a given test ullage mass value. This menu item is only available if you set up a conversion (mass) table in menu item C3.1 Edit Table. Make sure that menu item C4.1.1 Current Out. 1 Var. is set to "Ullage Mass" before the device simulates a mass value. This procedure sends an output signal that agrees with the test reading. Output will change to the selected value, independent of the measurement data.</p> <p>When you push [←] to confirm the value, the display shows the question "Start Simulation?" Push [▼] or [▲] to set the display to "Yes". Push [←] again to start the test. The device goes to back to Normal mode after 1 hour.</p> <p>Minimum access level to do the procedure: Expert</p>	min-max: 0...10.000 ⁺⁰⁹ kg	①

Menu No.	Function	Function description	Selection list	Default
B1.2 Output				
B1.2.1	Current Output 1	<p>This sets analogue output 1 to a test value [mA]. Output will change to the selected value, independent of the measured value.</p> <p>When you push [←] to confirm the value, the display shows the question "Start Simulation?" Push [▼] or [▲] to set the display to "Yes". Push [←] again to start the test. The device goes to back to Normal mode after 1 hour.</p> <p>Minimum access level to do the procedure: Expert</p>	3.6...21.5 mA	①

B2 Actual Values

B2.1	Operating Time [s]	This is the total time that the device is energized in seconds.	Read only	—
B2.4	Level	This menu item shows the level readings measured at this time. This measurement data is shown with the units set in menu C7.5 Units .	Read only	—
B2.5	Distance	This menu item shows the distance readings measured at this time. This measurement data is shown with the units set in menu C7.5 Units .	Read only	—
B2.6	Reflection	This menu item shows the percentage of the emitted radar signal which makes a reflection on the surface of the tank contents and is received by the device. If the distance measured is less than 1 metre, then the reflection value is 0%.	Read only	—
B2.7	Level Lin.	This menu item shows the level readings (linearized) measured at this time. This measurement data is shown with the units set in menu C7.5 Units . This menu item is only available if you set up a linearization table in menu item C3.1 Edit Table .	Read only	—
B2.8	Volume	This menu item shows the volume readings measured at this time. This measurement data is shown with the units set in menu C7.5 Units . This menu item is only available if you set up a conversion (volume) table in menu item C3.1 Edit Table .	Read only	—
B2.9	Mass	This menu item shows the mass readings measured at this time. This measurement data is shown with the units set in menu C7.5 Units . This menu item is only available if you set up a conversion (mass) table in menu item C3.1 Edit Table .	Read only	—
B2.10	Distance Lin.	This menu item shows the distance readings (linearized) measured at this time. This measurement data is shown with the units set in menu C7.5 Units . This menu item is only available if you set up a linearization table in menu item C3.1 Edit Table .	Read only	—

Menu No.	Function	Function description	Selection list	Default
B2.11	Ullage Volume	This menu item shows the ullage volume readings measured at this time. This measurement data is shown with the units set in menu C7.5 Units . This menu item is only available if you set up a conversion (volume) table in menu item C3.1 Edit Table .	Read only	—
B2.12	Ullage Mass	This menu item shows the ullage mass readings measured at this time. This measurement data is shown with the units set in menu C7.5 Units . This menu item is only available if you set up a conversion (mass) table in menu item C3.1 Edit Table .	Read only	—
B2.13	Sensor Temp.	Temperature of the sensor electronics block.	Read only	—
B2.14	Converter Temp.	Temperature of the converter electronics block. Operation of display can stop if the temperature is below -20°C / -4°F or above $+70^{\circ}\text{C}$ / $+158^{\circ}\text{F}$.	Read only	—

B3 Power Spectrum

B3.2	Power Spectrum	This menu item shows the raw spectra data of the radar signal which makes a reflection on the surface of the tank contents and is received by the device. This data is shown as a graph of the percentage of the full-scale signal against distance.	Read only	—
B4 Corrected Spectrum				
B4.2	Corrected Spectrum	This menu item shows the corrected spectra data of the radar signal which makes a reflection on the surface of the tank contents and is received by the device. This is the result of the spectra data from an empty tank subtracted from the power spectra data. This data is shown as a graph of the percentage of the full-scale signal against distance.	Read only	—
B5 Empty Spectrum				
B5.2	Empty Spectrum	This menu item shows the spectra of the radar signal which makes a reflection on objects inside an empty tank (interference signals). This data is shown as a graph of the percentage of the full-scale signal against distance. It is also possible to do an empty spectrum scan in a partially full tank, if it is not possible to remove all the tank contents.	Read only	—

① The default value is the measured value at the time that you start the simulation

C – Full Setup menu

Menu No.	Function	Function description	Selection list	Default
----------	----------	----------------------	----------------	---------

C1 Install. Parameters

C1.1	Tank Type	The conditions in which the device is used. If the surface of the product is flat, select "Storage". If the surface of the product is disturbed, select "Process". If the surface of the product is agitated with vortexes and foam, select "Agitator". Minimum access level to change the setting: Expert	Agitator, Process, Storage	Process ①
C1.2	Tank Height	Tank height is the distance from the flange face/thread stop of the process connection to the tank bottom. If you use the device for an LPR (open-air) application, this value is the maximum distance that the device must measure (the measuring range). Minimum access level to change the setting: Expert	min-max: 0.0...100.00 ⁺⁰³ mm / 0.0...2362.2" / 0.0...196.85 ft	10000 mm / 393.701" / 32.808 ft ①
C1.5	Blocking Distance	The distance from the flange facing or the thread stop to the top limit of the measuring range (a zone given by the user where it is not possible to measure). We recommend a minimum blocking distance of 100 mm / 4" below the bottom of the antenna. If the distance is less than the blocking distance, the device continues to show the blocking distance on the display screen. Minimum access level to change the setting: Expert	min-max: 0.0...5000.0 mm / 0.0...196.85" / 0.0...16.404 ft	DN25 Lens: Antenna extension length + 100 mm / 4" DN40 Lens: Antenna extension length + 200 mm / 4"
C1.6	Time Constant	Using this function, the device processes several measurement readings to filter out disturbances. Increasing the time constant will smoothen the integrated readings, decreasing will roughen the readings. s = seconds. Minimum access level to change the setting: Expert	min-max: 0....100.0 sec (seconds)	3 s
C1.7	Antenna Type	The type of antenna attached to the device. If you change the antenna, this setting will have an effect on C1.2 Tank Height and C1.5 Blocking Distance. Minimum access level to change the setting: Expert	Lens (25mm), Lens (40mm)	As specified in the customer order
C1.8	Antenna Extension	Optional antenna extension. These are attached between the flange and the antenna. Each segment is 105 mm / 4.1" long. Minimum access level to change the setting: Expert	min-max: 0.0...1050 mm / 0.0...41.339" / 0.0...3.4449 ft	0 mm / 0" ①
C1.9	Distance piece	Optional distance piece between the converter and the process connection. This is for the high-temperature version of the device. Each segment is 105 mm / 4.1" long. Minimum access level to change the setting: Expert	min-max: 0.0...2000 mm / 0.0...78.740" / 0.0...6.5617 ft	0 mm / 0" ①

Menu No.	Function	Function description	Selection list	Default
C1.10	Reference Offset	Offset relating to a reference location (distance). This value is positive when the reference location is above the device flange face and negative if below. For more data, refer to <i>Distance measurement</i> on page 95. Minimum access level to change the setting: Expert	min-max: -5000.0...+5000.0 m / -196.85 ⁺⁰³ ...+196.85 ⁺⁰³ / -16404...+16404 ft	0 m / 0 ft
C1.11	Tank Bottom Offset	Offset relating to a reference location (level). The device reference point for this parameter is the bottom of the tank (set in menu item C1.2 Tank Height). This value is positive when the reference location is below the tank bottom and negative if above. For more data, refer to <i>Level measurement</i> on page 97. Minimum access level to change the setting: Expert	min-max: -5000.0...+5000.0 m / -196.85 ⁺⁰³ ...+196.85 ⁺⁰³ / -16404...+16404 ft	0 m / 0 ft

C2 Process

C2.1	Tracking Velocity	This menu item sets the maximum rate of change of level in metres per minute or feet per minute. The measured value cannot change faster than the tracking velocity. Minimum access level to change the setting: Expert	min-max: 1.2 ⁻⁰³ ...60.0 m/min / 3.94 ⁻⁰³ ...196.85 ft/min	500 ⁻⁰³ m/min / 1.64042 ft/min
C2.2	Epsilon R Product	The device automatically calculates the level based on the product ϵ_r . If you select "TBF Full" or "TBF Auto" in menu item C2.4 Measuring Mode, you can change this value manually to adjust readings. Minimum access level to change the setting: Expert	1.1...20	2.0
C2.3	Epsilon R Gas	A major parameter for radar level measurement devices. This can be applicable to high pressure applications or tanks that contain a specified gas. If the gas is not 1.0, set the ϵ_r value to the ϵ_r value of the gas. Minimum access level to change the setting: Expert	1.0...20	1.0

Menu No.	Function	Function description	Selection list	Default
C2.4	Measuring Mode	<p>In "Direct" mode, the level signal is a reflection on the surface of the tank contents. If the dielectric constant is very low, the device uses "TBF Auto" or "TBF Full" mode. The device in "TBF" mode uses the radar reflection on the bottom of the tank (the signal goes through the tank contents). The tank must have a flat bottom for the device to operate correctly in TBF mode. This menu item is set by default to "Direct" for tank contents with an $\epsilon_r > 1.4$. If ϵ_r is very low (< 1.4), use "TBF Full". If ϵ_r is low ($\epsilon_r = 1.4 \dots 1.5$), use "TBF Auto" mode. "TBF Auto" is an automatic mode that lets the device make a selection between "Direct" mode and "TBF" mode. If you use "TBF Full" or "TBF Auto", enter the dielectric constant in menu item C2.2 Epsilon R Product. Refer also to "Measuring principle" on page 115.</p> <p>Minimum access level to change the setting: Expert</p>	Direct, TBF Auto, TBF Full	Direct
C2.5	Overfill Detection	<p>If this function is in operation, the device will monitor the level even if it is in the blocking distance. The output shown on the display screen stays fixed at the blocking distance, but an error message will warn the user that the tank is too full.</p> <p>Minimum access level to change the setting: Expert</p>	Disabled, Enabled	Disabled ①
C2.6	Overfill Threshold	<p>If you have set menu item C2.5 Overfill Detection to "Enabled", this menu item will be available. If the device cannot easily measure in the blocking distance (see menu item C1.5), then you can change the overfill threshold. This value is a percentage of the radar signal amplitude. To enter the correct value, we recommend that you speak or write to your supplier.</p> <p>Minimum access level to change the setting: Expert</p>	min-max: 0.0...100.0%	10%
C2.7	Mult. Refl. Enable	<p>Multiple reflections will cause the device to display smaller level readings. Installation of the device on a manhole or at the centre of a dome roof, and high dielectric products ($\epsilon_r > 5$) can cause multiple reflections. A very calm surface or a tank with a small convex or flat roof can also cause multiple reflections.</p> <p>If this function is in operation, the device looks for the first signal peak below the process connection. This signal peak is then used to measure the level of the tank contents. If this function is not in operation, the device looks for the largest signal below the process connection.</p> <p>Minimum access level to change the setting: Expert</p>	Disabled, Enabled	Disabled ①

Menu No.	Function	Function description	Selection list	Default
C2.8	Empty Spectrum Enable	This function starts and stops the interference signal filter. Interference signals are the result of fixed and moving obstacles inside the tank. If you must do a spectrum analysis, record an empty spectrum first. Do the "Empty Spectrum" procedure (menu A4.2) in the Quick Setup menu. Minimum access level to change the setting: Expert	Disabled, Enabled	Disabled

C3 Conversion

C3.1 Edit Table				
C3.1.1	Erase Table?	Before you can make a conversion table, you must delete the data that is stored in the device at this time. If you set this menu item to "No" you will go back to menu C3.1. If you set it to "Yes", you will go to menu item C3.1.3 Select Conversion. Minimum access level to change the setting: Expert	Yes, No	No
C3.1.3	Select Conversion	If you must make a volume conversion table, set this menu item to "Volume". If you must make a mass conversion table, set this menu item to "Mass". If you must make a linearization table to make sure that the readings always agree with reference measurements, set this menu item to "Linearization". Minimum access level to change the setting: Expert	Volume, Mass, Linearization	Volume
C3.2 Input Table				
C3.2.2	Point	This adds a point on the conversion table. Each time you enter this menu item, this number will automatically increment by 1 point. If it is necessary to change the data for a point, change the point number. When you push [←], you go to menu item C3.2.4 Level. Minimum access level to do the procedure: Expert	min-max: 001...050	001
C3.2.4	Level	Enter the level value for the point given in C3.2.2. Push [←] to confirm the level value and go to C3.2.5 Conv. Value. Minimum access level to do the procedure: Expert	min-max: 0.0...100.0 ⁺⁰³ mm / 0.0...3937.0"	0.0 mm / 0.0"
C3.2.5	Conv. Value	Enter the conversion value (volume, mass or linearization) for the point given in C3.2.2. Push [←] to confirm the conversion value and go back to menu C3.2. Minimum access level to do the procedure: Expert	min-max: Volume: 0.0...100.0 ⁺⁰⁹ m ³ / 0.0...26.417 ⁺¹² gal Mass: 0.0...100.0 ⁺⁰⁹ kg / 0.0...220.46 ⁺⁰⁹ lb Linearization: 0.0...100.0 ⁺¹² mm / 0.0...3.937 ⁺¹² "	Volume: 0.0 m ³ / 0.0 gal Mass: 0.0 kg / 0.0 lb Linearization: 0.0 mm / 0.0"

Menu No.	Function	Function description	Selection list	Default
----------	----------	----------------------	----------------	---------

C4 Output

C4.1 Current Output 1				
C4.1.1	Current Out. 1 Var.	Make a selection from the available output functions to scale the current output values. This is not shown in Normal mode. Minimum access level to change the setting: Expert	Level, Distance, Sensor Value, Reflection ②	Level ①
C4.1.2	0% Range	Give a measurement value to 0% output (refer also to menu item C4.1.1 Current Out. 1 Var for the output function). 0% output = 4 mA. It is possible to have an output less than 4 mA (<0%) if you set C4.1.4 Current Out. Range to "3.8-20.5 mA". Minimum access level to change the setting: Expert	min-max: -4.9 ⁺⁰⁶ ...+5.1 ⁺⁰⁶ mm / -192.91 ⁺⁰³ ...+200.79 ⁺⁰³ / -16076...+16732 ft	0.0 mm ①
C4.1.3	100% Range	Give a measurement value to 100% output (refer also to menu item C4.1.1 Current Out. 1 Var for the output function). 100% output = 20 mA. It is possible to have an output more than 20 mA (>100%) if you set C4.1.4 Current Out. Range to "3.8-20.5 mA". Minimum access level to change the setting: Expert	min-max: -4.9 ⁺⁰⁶ ...+5.1 ⁺⁰⁶ mm / -192.91 ⁺⁰³ ...+200.79 ⁺⁰³ / -16076...+16732 ft	C1.2 Tank Height - C1.5 Blocking Distance ①
C4.1.4	Current Out. Range	This menu item sets the limits of the output current range to 1 of 4 available options: standard limits (4...20 mA), NAMUR NE 43-compliant limits (3.8...20.5 mA), reversed standard limits and reversed NAMUR NE 43-compliant limits. You use standard limits when you want the 0% output to be 4 mA and the 100% output to be 20 mA. You use reversed limits when you want the 0% output to be 20 mA and 100% output to be 4 mA. Minimum access level to change the setting: Expert	4-20 mA, 3.8-20.5 mA (NAMUR), 4-20 mA (reversed), 3.8-20.5 mA (reversed)	4-20 mA ①
C4.1.5	Error Function	This sets the behaviour of current output 1 if an error occurs. If this menu item is set to "Off", no signal is given (this parameter is not available if menu item C4.1.4 is set to "3.8-20.5 mA" (NAMUR) or "3.8-20.5 mA (reversed)"). If this menu item is set to "Hold", the output current stays at the value where the error occurred (this parameter is not available if menu item C4.1.4 is set to "3.8-20.5 mA" (NAMUR) or "3.8-20.5 mA (reversed)"). If this menu item is set to "Low", the output current changes to 3.5 mA (default value) if an error occurs. If this menu item is set to "High", the output current changes to 21.5 mA (default value) if an error occurs. You can change the low error current value in menu item C4.1.7. You can change the high error current value in menu item C4.1.8. Minimum access level to change the setting: Expert	Off, Low, High, Hold	Low ①

Menu No.	Function	Function description	Selection list	Default
C4.1.7	Low Error Current	This menu item is available if C4.1.5 Error Function is set to "Low". You can change the value to which the current output will change if an error occurs. Minimum access level to change the setting: Expert	min-max: 3.5...3.6 mA	3.5 mA
C4.1.8	High Error Current	This menu item is available if C4.1.5 Error Function is set to "High". You can change the value to which the current output will change if an error occurs. Minimum access level to change the setting: Expert	min-max: 21.0...21.5 mA	21.5 mA
C4.1.9 Trimming				
C4.1.9.2	4mA Trimming	Use this menu item if the current output of the device is set to 4 mA, but the measured loop current is not 4 mA. Enter the measured value. Minimum access level to change the setting: Expert	min-max: 0.0...25.0 mA	4 mA
C4.1.9.5	20mA Trimming	Use this menu item if the current output of the device is set to 20 mA, but the measured loop current is not 20 mA. Enter the measured value. Minimum access level to change the setting: Expert	min-max: 0.0...25.0 mA	20 mA

C5 Communication

C5.1 HART				
C5.1.1	Current Loop Mode	Set this menu item to "On" if the "Primary Variable" for current output 1 must also be transmitted as a 4...20 mA signal. If this menu item is set to "Off", this stops the 4...20 mA signal and starts HART® multi-drop mode. Minimum access level to change the setting: Expert	On, Off	On
C5.1.2 Identification				
C5.1.2.1	Polling Address	A polling address more than 0 will start HART® multi-drop mode. If you start HART® multi-drop mode, the current output stays constant at 4 mA. Minimum access level to change the setting: Operator	000...063	0
C5.1.2.2	Tag	Use this menu item to change the Tag name. It can have a maximum of 8 characters. For more data about the characters available, refer to <i>Keypad functions</i> on page 60 (values in menu items). Minimum access level to change the setting: Operator	—	TANK01

Menu No.	Function	Function description	Selection list	Default
C5.1.2.3	Long Tag	Use this menu item to change the long Tag name. It can have a maximum of 32 characters. For more data about the characters available, refer to <i>Keypad functions</i> on page 60 (values in menu items). Minimum access level to change the setting: Operator	—	—
C5.1.2.4	Manufacturer ID	This is the manufacturer ID number given to the supplier by the HART Foundation.	Read only	—
C5.1.2.5	Device Type	This is the device type number given to the supplier by the HART Foundation.	Read only	—
C5.1.2.6	Device ID	This is the device ID number given to the supplier by the HART Foundation. This shows that the HART Foundation registered the HART® device description (DD) file.	Read only	—
C5.1.2.7	Universal Revision	This is the version of the HART protocol used by the device.	Read only	—
C5.1.2.8	Device Revision	This is the revision number for the HART® device description.	Read only	—
C5.1.2.9	Software Revision	This is the revision number for the device software.	Read only	—
C5.1.2.10	Hardware Revision	This is the revision number for the device hardware.	Read only	—
C5.1.3 Device Information				
C5.1.3.1	Descriptor	You can give a short description (16 characters maximum) of the device in this menu item. Minimum access level to change the setting: Operator	—	—
C5.1.3.2	Message	You can give more data in this menu item (32 characters maximum). Minimum access level to change the setting: Operator	—	—
C5.1.3.3	Date	You can enter the date in this menu item (Format: Year-Month-Day / YYYY-MM-DD) Minimum access level to change the setting: Operator	—	2014-01-01
C5.1.3.4	Cfg. Change Counter	This function counts the number of changes to the HART® device settings	Read only	—
C5.1.4 HART Variables				
C5.1.4.1	Current Out. 1 Var.	This is the first measurement type shown on HART® controllers. Make a selection from the list. Minimum access level to change the setting: Expert	Level, Distance, Sensor Value, Reflection ②	Distance
C5.1.4.2	HART/sec./CO2 Var.	This is the second measurement type shown on HART® controllers. Make a selection from the list. Minimum access level to change the setting: Expert	Level, Distance, Sensor Value, Reflection ②	Level

Menu No.	Function	Function description	Selection list	Default
C5.1.4.3	Tertiary Var.	This is the third measurement type shown on HART® controllers. Make a selection from the list. Minimum access level to change the setting: User	Level, Distance, Sensor Value, Reflection ②	Reflection
C5.1.4.4	Quaternary Var.	This is the fourth measurement type shown on HART® controllers. Make a selection from the list. Minimum access level to change the setting: User	Level, Distance, Sensor Value, Reflection ②	Sensor Value

C6 Display

C6.1	Language	Data can be shown in one of the languages stored in the device. Make a selection from the list. Minimum access level to change the setting: User	English, German, French, Italian, Portuguese, Spanish, Czech, Polish, Chinese (simplified), Japanese, Russian, Turkish	English
C6.2	Backlight	If you set this menu item to "Enabled", a light comes on when you push a button on the display keypad and if the loop current is more than 6 mA. Minimum access level to change the setting: User	Disabled, Enabled	Enabled
C6.3	Contrast	The contrast control for the display screen. You can select a shade of grey between light grey (-10) and black (+10). Minimum access level to change the setting: User	min-max: -10...+10	0
C6.4 1st Meas. Page				
C6.4.1	Function	This menu item changes the configuration of data shown on the display screen in Normal mode. There are two measurement pages available to show readings in Normal mode. This setting is for the first page. Minimum access level to change the setting: User	One Value, One Value & Bar, Two Values, Two Values & Bar, Three Values	One Value & Bar
C6.4.2	1st Value Variable	This changes the measurement type of the first value on the measurement page. Minimum access level to change the setting: User	Level, Distance, Sensor Value, Reflection ②	Distance
C6.4.3	0% Range	This is the 0% value given to the bar graph indicator in Normal mode. The range is related to the measurement type set in C6.4.2 1st Value Variable. This menu item is only available if you set C6.4.1 Function to "One Value & Bar" or "Two Values & Bar". Minimum access level to change the setting: User	Refer to "Function description".	Refer to "Function description".

Menu No.	Function	Function description	Selection list	Default
C6.4.4	100% Range	This is the 100% value given to the bar graph indicator in Normal mode. The range is related to the measurement type set in C6.4.2 1st Value Variable. This menu item is only available if you set C6.4.1 Function to "One Value & Bar" or "Two Values & Bar". Minimum access level to change the setting: User	Refer to "Function description".	Refer to "Function description".
C6.4.5	Format 1st Value	You can change the number of decimal places that are shown for the first value on the measurement page in Normal mode. For example, if you set this menu item to "X.XX", the value shown will be corrected to 2 decimal places. If you set this menu item to "Automatic", the device will adjust the number of decimal places automatically. Minimum access level to change the setting: User	X, X.X, X.XX, X.XXX, X.XXXX, X.XXXXX, X.XXXXXXX, Automatic	X.XXX
C6.4.6	2nd Value Variable	This changes the measurement type of the second value on the measurement page. This menu item is only available if you set C6.4.1 Function to "Two Values", "Two Values & Bar" or "Three Values". Minimum access level to change the setting: User	Level, Distance, Sensor Value, Reflection ②	Level
C6.4.7	Format 2nd Value	You can change the number of decimal places that are shown for the second value on the measurement page in Normal mode. For example, if you set this menu item to "X.XX", the value shown will be corrected to 2 decimal places. If you set this menu item to "Automatic", the device will adjust the number of decimal places automatically. Minimum access level to change the setting: User	X, X.X, X.XX, X.XXX, X.XXXX, X.XXXXX, X.XXXXXXX, Automatic	X.XXX
C6.4.8	3rd Value Variable	This changes the measurement type of the third value on the measurement page. This menu item is only available if you set C6.4.1 Function to "Three Values". Minimum access level to change the setting: User	Level, Distance, Sensor Value, Reflection ②	Reflection
C6.4.9	Format 3rd Value	You can change the number of decimal places that are shown for the second value on the measurement page in Normal mode. For example, if you set this menu item to "X.XX", the value shown will be corrected to 2 decimal places. If you set this menu item to "Automatic", the device will adjust the number of decimal places automatically. Minimum access level to change the setting: User	X, X.X, X.XX, X.XXX, X.XXXX, X.XXXXX, X.XXXXXXX, Automatic	X.XXX

Menu No.	Function	Function description	Selection list	Default
C6.5 2nd Meas. Page				
C6.5.1	Function	This menu item changes the configuration of data shown on the display screen in Normal mode. There are two measurement pages available to show readings in Normal mode. This setting is for the second page. Minimum access level to change the setting: User	One Value, One Value & Bar, Two Values, Two Values & Bar, Three Values	Three Values
C6.5.2	1st Value Variable	This changes the measurement type of the first value on the measurement page. Minimum access level to change the setting: User	Level, Distance, Sensor Value, Reflection ②	Distance
C6.5.3	0% Range	This is the 0% value given to the bar graph indicator in Normal mode. The range is related to the measurement type set in C6.4.2 1st Value Variable. This menu item is only available if you set C6.4.1 Function to "One Value & Bar" or "Two Values & Bar". Minimum access level to change the setting: User	Refer to "Function description".	Refer to "Function description".
C6.5.4	100% Range	This is the 100% value given to the bar graph indicator in Normal mode. The range is related to the measurement type set in C6.4.2 1st Value Variable. This menu item is only available if you set C6.4.1 Function to "One Value & Bar" or "Two Values & Bar". Minimum access level to change the setting: User	Refer to "Function description".	Refer to "Function description".
C6.5.5	Format 1st Value	You can change the number of decimal places that are shown for the first value on the measurement page in Normal mode. For example, if you set this menu item to "X.XX", the value shown will be corrected to 2 decimal places. If you set this menu item to "Automatic", the device will adjust the number of decimal places automatically. Minimum access level to change the setting: User	X, X.X, X.XX, X.XXX, X.XXXX, X.XXXXX, X.XXXXXXX, Automatic	X.XXX
C6.5.6	2nd Value Variable	This changes the measurement type of the second value on the measurement page. This menu item is only available if you set C6.4.1 Function to "Two Values", "Two Values & Bar" or "Three Values". Minimum access level to change the setting: User	Level, Distance, Sensor Value, Reflection ②	Level
C6.5.7	Format 2nd Value	You can change the number of decimal places that are shown for the second value on the measurement page in Normal mode. For example, if you set this menu item to "X.XX", the value shown will be corrected to 2 decimal places. If you set this menu item to "Automatic", the device will adjust the number of decimal places automatically. Minimum access level to change the setting: User	X, X.X, X.XX, X.XXX, X.XXXX, X.XXXXX, X.XXXXXXX	X.XXX

Menu No.	Function	Function description	Selection list	Default
C6.5.8	3rd Value Variable	This changes the measurement type of the third value on the measurement page. This menu item is only available if you set C6.4.1 Function to "Three Values". Minimum access level to change the setting: User	Level, Distance, Sensor Value, Reflection ②	Reflection
C6.5.9	Format 3rd Value	You can change the number of decimal places that are shown for the second value on the measurement page in Normal mode. For example, if you set this menu item to "X.XX", the value shown will be corrected to 2 decimal places. If you set this menu item to "Automatic", the device will adjust the number of decimal places automatically. Minimum access level to change the setting: User	X, X.X, X.XX, X.XXX, X.XXXX, X.XXXXX, X.XXXXXXX, Automatic	Automatic

C7 Device

C7.1 Information				
C7.1.1	Tag	Use this menu item to read the Tag name.	Read only	TANK01 ①
C7.1.2	Serial Number	This is the device fabrication number	Read only	—
C7.1.3	Device Name	This gives the device family name and model code.	Read only	—
C7.1.4	V Number	This is the manufacturer's option code for device configuration.	Read only	—
C7.1.5	Electronic Revision	This is the hardware revision number. This number agrees with NAMUR NE 53 Guidelines.	Read only	—
C7.1.6	Software Revision	This is the software revision number. This number agrees with NAMUR NE 53 Guidelines.	Read only	—
C7.1.7	Electronic Serial No.	This is the hardware fabrication number. This number agrees with NAMUR NE 53 Guidelines.	Read only	—
C7.1.8	Production Date	This the date that the manufacturer finished the device. The date format is: Year-Month-Day.	Read only	—
C7.1.9	Calibration Date	This the date that the manufacturer calibrated the device. The date format is: Year-Month-Day.	Read only	—
C7.2 Security				
C7.2.1	Login	Enter the appropriate password here to change settings. If you do not enter the password, you can only change settings for the "user" access level. For more data and the default passwords for the "operator" and "expert" access levels, refer to <i>Protection of the device settings (access levels)</i> on page 57.	4-digit hexadecimal password	Refer to "Function description"
C7.2.2	Change Password	This changes the password for the "operator" and "expert" access levels. For the procedure to change the password, refer to <i>Protection of the device settings (access levels)</i> on page 57 (How to change the password).	4-digit hexadecimal password	Refer to "Function description"

Menu No.	Function	Function description	Selection list	Default
C7.2.3	Reset Passwords	This is a special password that makes your passwords for the "operator" and "expert" access levels go back to the default passwords. This password is supplied on request by the after-sales service department.	—	—
C7.2.4	Unlock Extended Range	This menu item can only be unlocked at the factory.	—	—
C7.2.5	Unlock SIL	This menu item can only be unlocked at the factory.	—	—
C7.3 Errors				
C7.3.1	Message View	A log of device errors. Scroll down the list and push [➤] to show the error details. The error will have a letter code ("F", "S", "M", "C" and "I") that agrees with NAMUR NE 107 Guidelines.	Read only	—
C7.3.2 Error-Mapping				
C7.3.2.1	Sensor: Information	This permits you to change the error code that is given to an incident. Minimum access level to change the setting: User	None, Information (I), Maintenance Request (M), Out of Specification (S), Function Check (C), Failure (F)	Information
C7.5 Units				
C7.5.1	Length	The length unit shown in Normal mode. If you set this menu item to "Cst." (custom length unit), enter values in menu items C7.5.2.1 thru C7.5.2.3. Minimum access level to change the setting: User	m, cm, mm, ft, in, Cst.	m
C7.5.2 Cst. Length				
C7.5.2.1	Text	Enter a text (8 characters maximum) for the custom length unit.	—	Cst.
C7.5.2.2	Offset	Enter an offset value.	—	0.0 m
C7.5.2.3	Factor	Enter a factor. Multiply the measured value by this factor to change m (metres) to the custom length unit.	—	1.0
C7.5.3	Volume	The volume unit shown in Normal mode if you made a volume table in the C3 Conversion menu. If you set this menu item to "Cst. Volume" (custom volume unit), enter values in menu items C7.5.4.1 thru C7.5.4.3. Minimum access level to change the setting: User	m ³ , L, hL, in ³ , ft ³ , gal, ImpGal, yd ³ , bbl, bbl (beer, US), Cst. Volume	m ³
C7.5.4 Cst. Volume				
C7.5.4.1	Text	Enter a text (8 characters maximum) for the custom volume unit.	—	Cst.
C7.5.4.2	Offset	Enter an offset value.	—	0.0 m ³
C7.5.4.3	Factor	Enter a factor. Multiply the measured value by this factor to change m ³ (cubic metres) to the custom volume unit.	—	1.0

Menu No.	Function	Function description	Selection list	Default
C7.5.5	Mass	The mass unit shown in Normal mode if you made a mass table in the C3 Conversion menu. If you set this menu item to "Cst. Mass" (custom mass unit), enter values in menu items C7.5.6.1 thru C7.5.6.3. Minimum access level to change the setting: User	kg, t, lb, tn.sh., tn.l., Cst. Mass	kg
C7.5.6 Cst. Mass				
C7.5.6.1	Text	Enter a text (8 characters maximum) for the custom volume unit.	—	Cst.
C7.5.6.2	Offset	Enter an offset value.	—	0.0kg
C7.5.6.3	Factor	Enter a factor. Multiply the measured value by this factor to change kg (kilogram) to the custom mass unit.	—	1.0
C7.6 Factory Default				
C7.6.1	Reset to Fact. Def.?	If you set this menu item to "YES", the device goes back to its initial settings (set by the manufacturer in the factory). Minimum access level to change the setting: Expert	Yes, No	No

① If no value or parameter is specified in the customer order

② "Lin. Distance" and "Lin. Level" are available if you created a linearized value table in menu C3 Conversion. "Volume" and "Ullage Volume" are available if you created a level-volume table in menu C3 Conversion. "Mass" and "Ullage Mass" are available if you created a level-mass table in menu C3 Conversion.

6.4 Further information on device configuration in Program mode

6.4.1 Standard setup

Use this procedure (menu item A4.1 Standard Setup) to change the length unit, tank type, tank height, current output variable, 0% range, 100% range, current output range and error function. Values and parameters that can be changed are shown between the « ... » marks in the illustrations that follow. Push the keypad buttons in the correct sequence:



CAUTION!

Make sure that you do this procedure before you use the device. The settings in this procedure have an effect on the performance of the device.





INFORMATION!

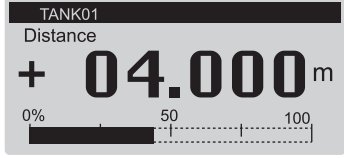
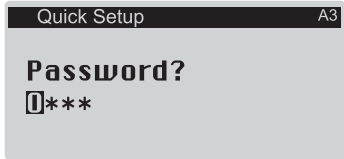
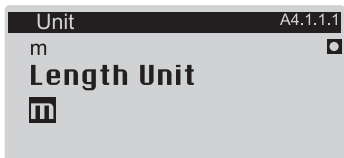
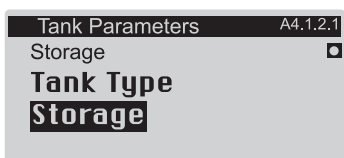
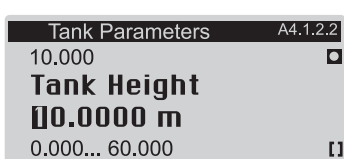
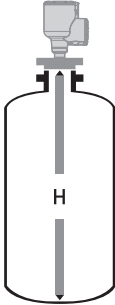
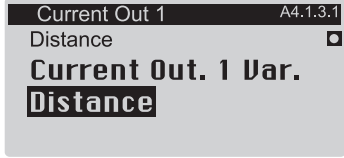

Current output and LCD display settings

*When you do the **Standard setup** procedure, the measurement value on the first measurement page of the LCD display (in Normal mode) automatically uses settings with the same parameters and values as the current output settings (measurement variable, 0% range and 100% range). The first measurement page shows "one value and bar" by default. If you must show one or more measurement values that are different to the transmitted output signal, change the settings in the C6.4 1st Meas. Page and C6.5 2nd Meas. Page menus. For more data, refer to Function description on page 70 – table C. Full Setup menu (C6 Display).*

Procedure

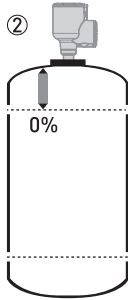
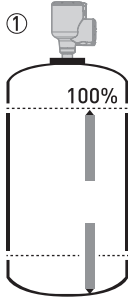
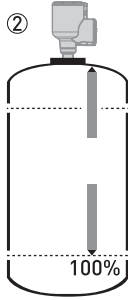
Screen	Steps	Description
	<ul style="list-style-type: none"> • 2 × [➤], 2 × [▼] and [➤]. 	<p>Default screen.</p> <p>Enter Program mode and go to menu item A3 Login.</p>
	<ul style="list-style-type: none"> • If it is the default password: 2 × [➤], 5 × [▲], [➤] and 8 × [▲] • [←] to confirm. 	<p>Enter the password used at this time for the "Expert" access level. If it is the default password, enter "0058".</p>
	<ul style="list-style-type: none"> • [▼] and 2 × [➤] • [▲] or [▼] for the selection of the length unit (m, Cst., in, ft, mm or cm). • [←] to confirm. 	<p>Push these buttons to start the Standard Setup procedure.</p> <p>Length unit. Make a selection from the list of parameters.</p>
	<ul style="list-style-type: none"> • [▲] or [▼] for the selection of the tank type (Storage, Stilling Well, Agitator or Process). • [←] to confirm. 	<p>Tank type. Make a selection from the list of parameters. If the surface of the product is flat, select "Storage". If the surface of the product is disturbed, select "Process". If the surface of the product is agitated with vortexes and foam, select "Agitator".</p>
	<ul style="list-style-type: none"> • [➤] to change the position of the cursor. • [▼] to decrease the value (or move the decimal point one digit to the left) or [▲] to increase the value (or move the decimal point one digit to the right). • [←] to confirm. 	<p>Tank height. The distance from the flange face / thread stop of the tank connection down to the tank bottom. If the tank has a dish-shaped or conical bottom, the tank height is measured to a point on the tank bottom directly below the antenna.</p> 
	<ul style="list-style-type: none"> • [▲] or [▼] for the selection of the measurement name (Distance, Level, Sensor Value or Reflection, Volume (Mass), Ullage Volume (Ullage Volume). • [←] to confirm. 	<p>Current output 1 variable. The manufacturer sets the current output variable (for current output 1) to "Distance" before delivery.</p> <p>If it is necessary to measure volume, ullage volume, mass or ullage mass, refer to <i>How to configure the device to measure volume or mass</i> on page 99.</p>

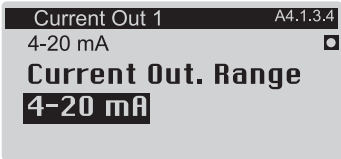
Screen	Steps	Description
<div style="border: 1px solid black; padding: 5px;"> <p>Current Out 1 A4.1.3.2</p> <p>0.0000 ▣</p> <p>0% Range</p> <p>+0.00000 m</p> <p>-4900.0... +5100.0 []</p> </div>	<ul style="list-style-type: none"> • [➤] to change the position of the cursor. • [▼] to decrease the value (or move the decimal point one digit to the left) or [▲] to increase the value (or move the decimal point one digit to the right). • [←] to confirm. 	<p>0% range. Use this step to give the 0% output setting in the tank.</p> <p>Refer to the illustrations that follow. When menu item A4.1.3.1 Current Out. 1 Var. is set to "Level", illustration ① shows the position of 0% output as a level above the tank bottom. When menu item A4.1.3.1 Current Out. 1 Var. is set to "Distance", illustration ② shows the position of 0% output as a distance below the flange facing or thread stop of the process connection.</p> <div style="display: flex; justify-content: space-around; align-items: center;"> <div style="text-align: center;"> <p>①</p>  </div> <div style="text-align: center;"> <p>②</p>  </div> </div>
<div style="border: 1px solid black; padding: 5px;"> <p>Current Out 1 A4.1.3.3</p> <p>10.000 ▣</p> <p>100% Range</p> <p>+10.0000 m</p> <p>-4900.0... +5100.0 []</p> </div>	<ul style="list-style-type: none"> • [➤] to change the position of the cursor. • [▼] to decrease the value (or move the decimal point one digit to the left) or [▲] to increase the value (or move the decimal point one digit to the right). • [←] to confirm. 	<p>100% range. Use this step to give the 100% output setting in the tank. Refer to the illustrations that follow. Illustration ① shows the settings for level. Illustration ② shows the settings for distance.</p> <p>Refer to the illustrations that follow. When menu item A4.1.3.1 Current Out. 1 Var. is set to "Level", illustration ① shows the position of 100% output as a level above the tank bottom. When menu item A4.1.3.1 Current Out. 1 Var. is set to "Distance", illustration ② shows the position of 100% output as a distance below the flange facing or thread stop of the process connection.</p> <div style="display: flex; justify-content: space-around; align-items: center;"> <div style="text-align: center;"> <p>①</p>  </div> <div style="text-align: center;"> <p>②</p>  </div> </div>

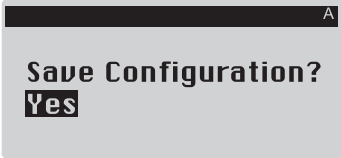
Screen	Steps	Description
 <p>Current Out 1 A4.1.3.4 4-20 mA Current Out. Range 4-20 mA</p>	<ul style="list-style-type: none"> [▲] or [▼] for the selection of the current output range (3.8-20.5 mA (NAMUR), 4-20 mA, 3.8-20.5 mA (reversed) or 4-20 mA (reversed)). [←] to confirm. 	<p>Current output range. This menu item gives current output values to the measuring range between 0% and 100% values given in the "0% range" and "100% range" steps.</p> <p>If you set this menu item to "4-20 mA" or "3.8-20.5 mA":</p> <ul style="list-style-type: none"> 0% Range = 4 mA 100% Range = 20 mA <p>If you set this menu item to "4-20 mA (reversed)" or "3.8-20.5 mA (reversed)":</p> <ul style="list-style-type: none"> 0% Range = 20 mA 100% Range = 4 mA
 <p>Current Out 1 A4.1.3.5 Low Error Function High</p>	<ul style="list-style-type: none"> [▲] or [▼] for the selection of the error function (Off, Hold, High or Low). [←] to confirm. 	<p>Error Function. This sets the behaviour of current output 1 if an error occurs.</p> <p>If this menu item is set to "Off", no signal is given (this parameter is not available if menu item C4.1.4 is set to "3.8-20.5 mA" (NAMUR) or "3.8-20.5 mA (reversed)"). If this menu item is set to "Hold", the output current stays at the value where the error occurred (this parameter is not available if menu item C4.1.4 is set to "3.8-20.5 mA" (NAMUR) or "3.8-20.5 mA (reversed)"). If this menu item is set to "Low", the output current changes to 3.5 mA (default value) if an error occurs. If this menu item is set to "High", the output current changes to 21.5 mA (default value) if an error occurs.</p>
 <p>Save Configuration? Yes</p>	<ul style="list-style-type: none"> 3 × [←] to confirm. [▲] or [▼] for the selection of the save option (Yes, No or Back). [←] to confirm. 	<p>Save Configuration? screen.</p> <p>Set to "Yes" to save and use the settings and data and go back to Normal mode. Set to "No" to cancel the changes to the device settings and go back to Normal mode. Set to "Back" to stay in Program mode.</p>

6.4.2 Empty spectrum recording

The empty spectrum recording procedure is important for the performance of the device. We recommend that the tank is empty or only filled to the minimum level before you do the procedure.

Use this procedure (menu item A4.2 Empty Spectrum) if there are fixed and moving objects in the tank that can cause interference signals. The device does a scan for objects that do not change their vertical positions in the tank (heating tubes, agitators, fuel assemblies etc.) and records the data. The device can then use this data to put the measurement signal through a filter (empty spectrum).

When the empty spectrum filter is on (when menu item C2.8 Empty Spectrum Enable is set to "Enable"), it will ignore the interference signals.



CAUTION!

Make sure that the tank is empty or only filled to the minimum level.



INFORMATION!



Because the device records the empty spectrum data, it is not necessary to do the procedure again if you de-energize the device.

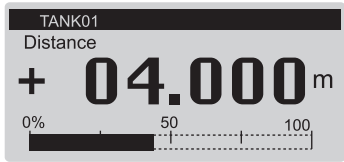
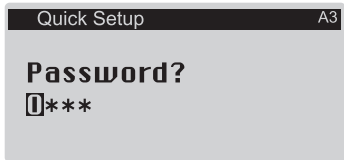

Before you do the empty spectrum recording procedure, install the device on the tank. For more data about how to install the device, refer to *Installation* on page 21.

Values and parameters that can be changed are shown between the « ... » marks in the illustrations that follow. Push the keypad buttons in the correct sequence:

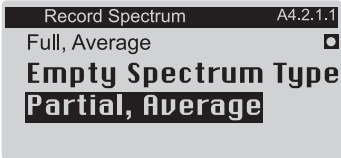
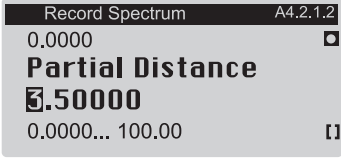
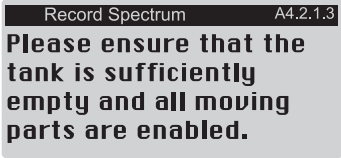
Procedure

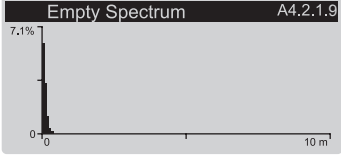
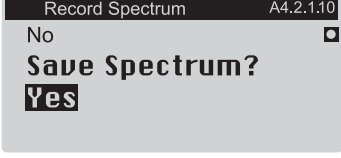
Screen	Steps	Description
	<ul style="list-style-type: none"> • 2 × [➤], 2 × [▼] and [➤]. 	<p>Default screen.</p> <p>Enter Program mode and go to menu item A3 Login.</p>
	<ul style="list-style-type: none"> • If it is the default password: 2 × [➤], 5 × [▲], [➤] and 8 × [▲] • [←] to confirm. 	<p>Enter the password used at this time for the "Expert" access level. If it is the default password, enter "0058".</p>

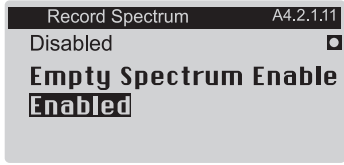
Screen	Steps	Description
	<ul style="list-style-type: none"> • [▼], [>], [▼] and 2 × [>]. • [▲] or [▼] for the selection of the empty spectrum type (Full (Average), Full (Max), Partial (Average), Partial (Max)). • [←] to confirm. 	<p>Push these buttons to start the Record Spectrum (Empty Spectrum) procedure.</p> <p>Empty spectrum type. Make a selection from the list of parameters. If you can empty the tank, set this menu item to "Full, Average" or "Full, Max". If you cannot empty the tank, set this menu item to "Partial, Average" or "Partial, Max".</p> <p>If you set Tank Type in the Standard Setup procedure or in menu item C1.1 to "Agitator", set Empty Spectrum Type to "Full, Max" or "Partial, Max". If the device is near to a product inlet, set Empty Spectrum Type to "Full, Max" or "Partial, Max".</p>
	<ul style="list-style-type: none"> • [>] to change the position of the cursor. • [▼] to decrease the value (or move the decimal point one digit to the left) or [▲] to increase the value (or move the decimal point one digit to the right). • [←] to confirm. 	<p>Partial distance. If you set Empty Spectrum Type to "Partial, Average" or "Partial, Max", you will have one more step to do in this procedure. You must give a "partial distance" value less than or equal to the distance to the product surface from the flange facing or thread stop of the process connection.</p> <p>CAUTION! If the "partial distance" value is more than the distance to the product surface, then the device will filter the level signal and the device will not measure the level of the product correctly.</p>
	<ul style="list-style-type: none"> • [←] to confirm. 	<p>Make sure that the tank is empty or it contains not more than the minimum quantity. Energize and operate all equipment that moves in the tank (e.g. agitators).</p>
	<ul style="list-style-type: none"> • [▼] or [▲] to change the parameter ("No" or "Yes"). • [←] to confirm. 	<p>Start recording? Set this menu item to "Yes" to continue to the subsequent step. Set this menu item to "No" to go back to the menu.</p>
	<ul style="list-style-type: none"> • [←] to confirm. 	<p>Graph with the results of the empty spectrum recording.</p>
	<ul style="list-style-type: none"> • [▼] or [▲] to change the parameter ("No" or "Yes"). • [←] to confirm. 	<p>Save spectrum? If you set the menu item to "Yes", the device will keep this empty spectrum recording. If you set the menu item to "No", the device will reject this data.</p>

Screen	Steps	Description
	<ul style="list-style-type: none"> • [▼] or [▲] to change the parameter ("Disable" or "Enable"). • [↵] to confirm. 	Empty Spectrum Enable. If you set the menu item to "Enable", the device will use the empty spectrum recording data. If you set the menu item to "Disable", the device will not use the empty recording data at this time.
	<ul style="list-style-type: none"> • 4 × [↵] to confirm. • [▲] or [▼] for the selection of the save option (Yes, No or Back). • [↵] to confirm. 	Save Configuration? screen. Set to "Yes" to save and use the settings and data and go back to Normal mode. Set to "No" to cancel the changes to the device settings and go back to Normal mode. Set to "Back" to stay in Program mode.

6.4.3 HART® network configuration



INFORMATION!

For more data, refer to *Networks* on page 45.

The device uses HART® communication to send information to HART®-compatible equipment. It can operate in either point-to-point or multi-drop mode. The device will communicate in multi-drop mode if you change the polling address.



CAUTION!

Make sure that the address for this device is different from others in the multi-drop network.



INFORMATION!

Make sure that menu item C5.1.1 Current Loop Mode is set to "On".



How to change from point-to-point to multi-drop mode

- Enter Program mode.
- Push 2 × [▼], [➤], 3 × [▼], 2 × [➤], [▼] and 2 × [➤] to go to menu item C5.1.2.1 Polling Address.
- Enter the password used at this time for the "Expert" access level. If it is the default password, enter "0058". Push [↵] to confirm.
- Enter a value between 001 and 063 and push [↵] to confirm.
- Push [↵] again and again to go back to the **Save Configuration?** screen.
- Push [▲] or [▼] to set the screen to "Yes" and push [↵].
- ➡ The output is set to multi-drop mode. The current output is set to 4 mA. This value does not change in multi-drop mode.



How to change from multi-drop to point-to-point mode

- Enter Program mode.
- Push 2 × [▼], [➤], 3 × [▼], 2 × [➤], [▼] and 2 × [➤] to go to menu item C5.1.2.1 Polling Address.
- Enter the password used at this time for the "Expert" access level. If it is the default password, enter "0058". Push [↵] to confirm.
- Enter the value 000 and push [↵] to confirm.
- Push [↵] again and again to go back to the **Save Configuration?** screen.

- Push [▲] or [▼] to set the screen to "Yes" and push [←].
- The output is set to point-to-point mode. The current output changes to a range of 4...20 mA or 3.8...20.5 mA (this range is set in menu item C4.1.4 Current Out. Range).

6.4.4 Distance measurement

The device gives a current output signal that is related to distance measurements when the menu item **C4.1.1 Current Out. 1 Var. (Current Output 1 Variable)** is set to "Distance".

The display screen of the device can show distance measurement readings if one or more of the "Value Variable" menu items in the C6.4 1st Measurement Page or C6.5 2nd Measurement Page menu are set to "Distance".

Menu items related to distance measurement are:

- Current output 1 menu (C4.1)
- Tank Height (C1.2)
- Blocking Distance (C1.5)
- Reference Offset (C1.10)
- **Display readings in Normal mode:** 1st Meas. Page (C6.4) menu
- **Display readings in Normal mode:** 2nd Meas. Page (C6.5) menu

The flange facing is the reference point for distance measurement (0 m / 0 ft / 0"). The position of the measurement scale (specified by the 0% Range and 100% Range settings) is related to this reference point. If you configured a measurement scale for the current output signal in the C4.1 Current output 1 menu, you can use a "standard scale" or a "reversed scale". On the standard scale, the 0% Range measurement value agrees with an output of 4 mA and the 100% Range measurement value agrees with an output of 20 mA. On the reversed scale, the 0% Range measurement value agrees with an output of 20 mA and the 100% Range measurement value agrees with an output of 4 mA.

You can change the reference point from which distance is measured. Use this menu item:

- Reference Offset (C1.10)



INFORMATION!

Menu item C1.10 Reference Offset

If you move the reference point above the flange, make sure that you add the value given in menu item C1.10 Reference Offset when you give a distance for the C4.1.2 0% Range and C4.1.3 100% Range settings. If you move the reference point below the flange, subtract the value given in menu item C1.10 Reference Offset when you give a distance for the C4.1.2 0% Range and C4.1.3 100% Range settings.



CAUTION!

If C4.1.1 Current Out. 1 Var. is set to "Distance" and C4.1.2 0% Range (standard scale) is set in the blocking distance, then the device will not be able to use the full current output range.

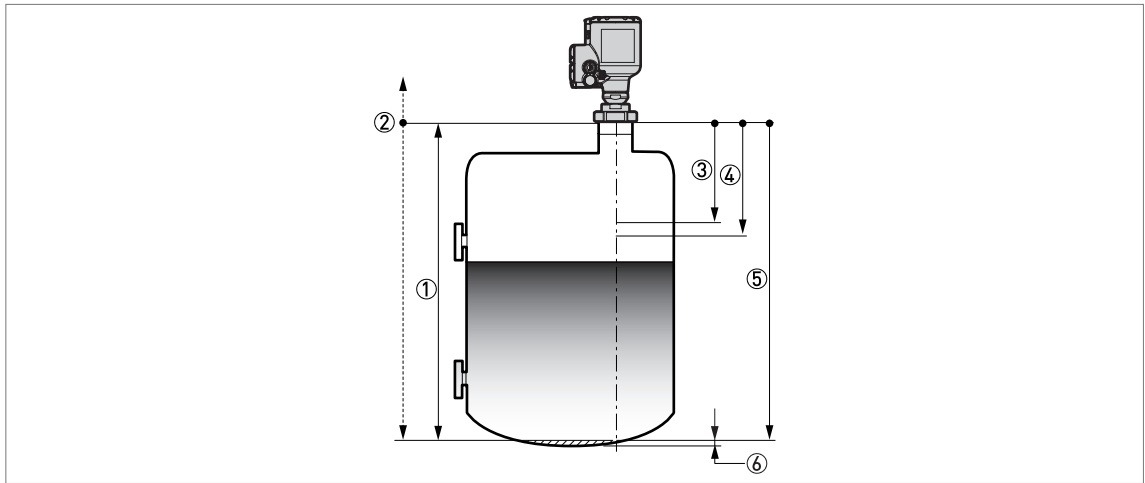

Figure 6-7: Distance measurement

- ① Tank Height [C1.2]
- ② Reference point. You can use menu item C1.10 Reference Offset to move the reference point.
- ③ Blocking Distance [C1.5]
- ④ 0% Range [C4.1.2], if menu item C4.1.4 Current Out. Range is set to "4-20mA" or "3.8-20.5mA"
- ⑤ 100% Range [C4.1.3], if menu item C4.1.4 Current Out. Range is set to "4-20mA" or "3.8-20.5mA"
- ⑥ Non-measurement zone

For more data about the menu items, refer to *Function description* on page 70 – table C. Full Setup menu.



INFORMATION!

Bar graph function in Normal mode

There is an optional bar graph shown on the two measurement pages in Normal mode (set C6.4.1 / C6.5.1 (Function) to "One Value & Bar" or "Two Values & Bar"). By default, the bar graph on the 1st Measurement Page shows a value related to the measurement scale specified in the C4.1 Current output 1 menu. It is possible to give different measurement scales and measurement variables for the bar graphs in Normal mode. For more data, refer to *Function description* on page 70 – table C. Full Setup menu (C6 Display). The bar graph range is related to the parameters given in the menu item C6.4.2 and C6.5.2 (1st Value Variable) and menu C1 Install. Parameters.

If you change C1.10 Reference Offset, then we recommend that you change C6.4.3 / C6.5.3 (0% Range) and C6.4.4 / C6.5.4 (100% Range) by the same quantity.

6.4.5 Level measurement

The device gives a current output signal that is related to level measurements when the menu item **C4.1.1 Current Out. 1 Var. (Current Output 1 Variable)** is set to "Level".

The display screen of the device can show level measurement readings if one or more of the "Value Variable" menu items in the C6.4 1st Measurement Page or C6.5 2nd Measurement Page menu are set to "Level".

Menu items related to level measurement are:

- Current output 1 menu (C4.1)
- Tank Height (C1.2)
- Blocking Distance (C1.5)
- Tank Bottom Offset (C1.11)
- **Display readings in Normal mode:** 1st Meas. Page (C6.4) menu
- **Display readings in Normal mode:** 2nd Meas. Page (C6.5) menu

The tank bottom (specified in menu item C1.2 Tank Height) is the reference point for level measurement (0 m / 0 ft / 0"). The position of the measurement scale (specified by the 0% Range and 100% Range settings) is related to this reference point. If you configured a measurement scale for the current output signal in the C4.1 Current output 1 menu, you can use a "standard scale" or a "reversed scale". On the standard scale, the 0% Range measurement value agrees with an output of 4 mA and the 100% Range measurement value agrees with an output of 20 mA. On the reversed scale, the 0% Range measurement value agrees with an output of 20 mA and the 100% Range measurement value agrees with an output of 4 mA.

You can change the reference point from which level is measured. Use this menu item:

- Tank Bottom Offset (C1.11)



INFORMATION!

C1.11 Tank Bottom Offset

If you move the tank bottom offset below the tank bottom, add the value given in C1.11 Tank Bottom Offset when you give a level for the C4.1.2 0% Range and C4.1.3 100% Range settings. If you move the tank bottom offset above the tank bottom, subtract the value given in C1.11 Tank Bottom Offset when you give a level for the C4.1.2 0% Range and C4.1.3 100% Range settings.



CAUTION!

If C4.1.1 Current Out. 1 Var. is set to "Level" and C4.1.3 100% Range (standard scale) is set in the blocking distance, then the device will not be able to use the full current output range.

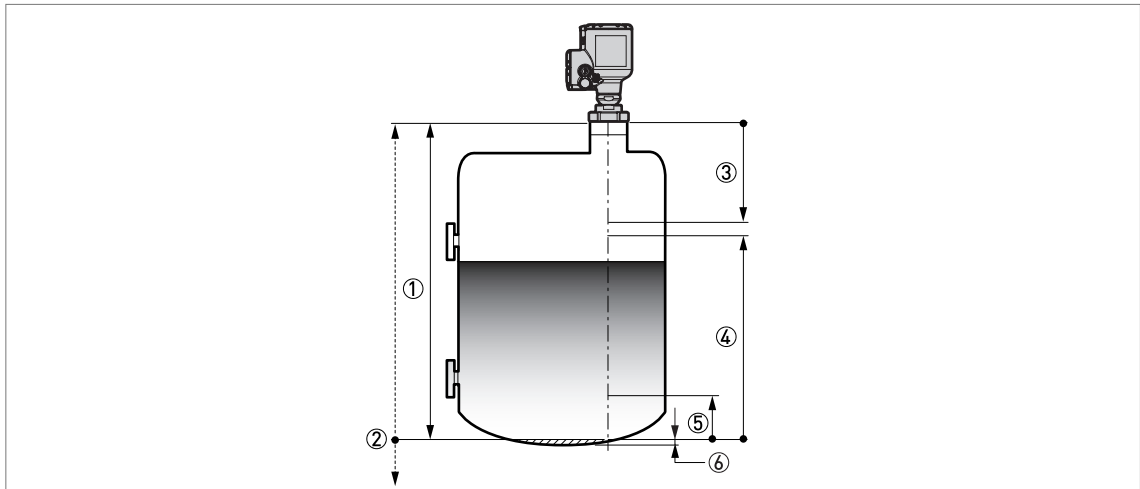

Figure 6-8: Level measurement

- ① Tank Height [C1.2]
- ② Tank bottom reference point. You can use menu item C1.11 Tank Bottom Offset to move the position of the tank bottom reference point.
- ③ Blocking Distance [C1.5]
- ④ 100% Range [C4.1.3], if menu item C4.1.4 Current Out. Range is set to "4-20mA" or "3.8-20.5mA"
- ⑤ 0% Range [C4.1.2], if menu item C4.1.4 Current Out. Range is set to "4-20mA" or "3.8-20.5mA"
- ⑥ Non-measurement zone

For more data about the menu items, refer to *Function description* on page 70 – table C. Full Setup menu.



INFORMATION!

Bar graph function in Normal mode

There is an optional bar graph shown on the two measurement pages in Normal mode (set C6.4.1 / C6.5.1 (Function) to "One Value & Bar" or "Two Values & Bar"). By default, the bar graph on the 1st Measurement Page shows a value related to the measurement scale specified in the C4.1 Current output 1 menu. It is possible to give different measurement scales and measurement variables for the bar graphs in Normal mode. For more data, refer to *Function description* on page 70 – table C. Full Setup menu (C6 Display). The bar graph range is related to the parameters given in the menu item C6.4.2 and C6.5.2 (1st Value Variable) and menu C1 Install. Parameters.

If you change C1.11 Tank Bottom Offset, then we recommend that you change C6.4.3 / C6.5.3 (0% Range) and C6.4.4 / C6.5.4 (100% Range) by the same quantity.

6.4.6 How to configure the device to measure volume or mass

The device can be configured to measure volume or mass. It can also be configured to a custom quantity to be measured. You can set up a strapping table in the conversion menu (C3 Conversion). Each entry is a pair of data (level – volume, level – mass or level – custom measurement). The strapping table must have a minimum of 2 entries and a maximum of 50. The reference point for the table is the bottom of the tank (as given in menu item Tank Height (C1.2)).



CAUTION!

Enter the data in numerical sequence (strapping table entry number 01, 02 etc.).



How to prepare a strapping table (conversion table)

- Enter Program mode.
- Push 2 × [▲], [>], 6 × [▲], [>], 3 × [▲] and 3 × [>] to go to C7.5.1 Length.
- Push [▲] and [▼] to find the length unit that you will use in the table.
- If it is necessary to make a volume table, push [←] to go back to the sub-menu level and then push 2 × [▲] and [>] to go to C7.5.3 Volume.
- Push [▲] and [▼] to find the volume unit that you will use in the table.
- Push 2 × [←] to go to sub-menu level "C7" and then 2 × [▲] and 2 × [>] to go to C7.2.1 Login. Enter the password used at this time for the "Expert" access level. If it is the default password, enter "0058".
- Push 3 × [←] to go to the sub-menu level "C" and then 4 × [▲], 2 × [>] to go to C3.1 Edit Table to delete strapping table data that the device uses at this time (Erase Table?). Push [▲] and [▼] to set this menu item to "Yes" to delete the data.
- Push [←] and then [▲] and [▼] to make a selection from the conversion table options (volume, mass or linearization).
- Push [←] to go to the sub-menu level and then [▼] and [>] to enter the first point on the table.
- Push [←] to make the strapping table.
- Enter the level value and push [←].
- Enter the conversion value and push [←] to go to the sub-menu level.
- Push [>] to enter the subsequent point (02, 03, ..., 50) on the table.
- Repeat the last 3 steps to complete the table.
- If the table is complete, push [←] again and again to go back to the "Save Configuration?" screen.
- The device will ask you to save or cancel your settings. Push [▲] or [▼] to make a selection from **Yes**, **No** or **Back**. **Back** makes the display go back to Program mode. If this screen is set to "Yes" or No", push [←] to accept (Yes) or reject (No) the new settings.
- ➡ If you push [←] when the screen is set to "Yes", the device will store the data for the strapping table and go back to Normal mode.

The device will give more accurate volume readings if you give more conversion data in these areas:

- Surfaces with curves.
- Sudden changes in the cross section.

Refer also to the illustration that follows:

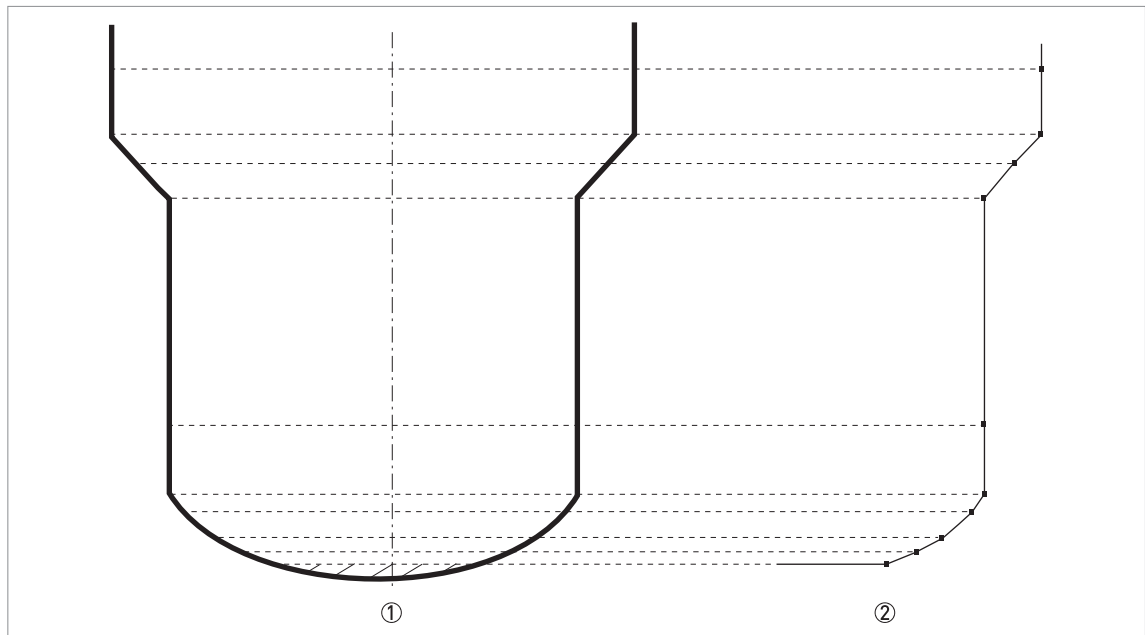

Figure 6-9: A plot of points for a volume or mass table

- ① Tank with reference points
- ② Tank model with plotted points



How to delete a volume or mass table

- Enter Program mode.
- Push $2 \times [\blacktriangle]$, $[\blacktriangleright]$, $2 \times [\blacktriangle]$ and $2 \times [\blacktriangleright]$ to go to C3.1.1 Erase Table?.
- To delete strapping table data that the device uses at this time (Erase Table?), push $[\blacktriangle]$ and $[\blacktriangledown]$ to set this menu item to "Yes".
- Push $[\blacktriangleleft]$ again and again to go back to the "Save Configuration?" screen.
- The device will ask you to save or cancel your settings. Push $[\blacktriangle]$ or $[\blacktriangledown]$ to make a selection from **Yes**, **No** or **Back**. **Back** makes the display go back to Program mode. If this screen is set to "Yes" or No", push $[\blacktriangleleft]$ to accept (Yes) or reject (No) the new settings.
- ➡ If you push $[\blacktriangleleft]$ when the screen is set to "Yes", the device will delete the data for the strapping table and go back to Normal mode.

6.4.7 How to measure correctly in tanks with curved or conical bottoms

It is possible that the device cannot find the bottom of the tank if it is installed in a tank with a dish-shaped or conical bottom. The form of the tank bottom causes a delayed radar reflection and the device will display the error message "Measurement is lost in the tank bottom".

You can offset the tank bottom reference point to find the delayed radar reflection. Obey the instructions that follow:



- Measure the true tank height with a different measurement method.
- Empty the tank.
- Enter Program mode and go to menu item C.1.2 Tank Height. Push the [>] button.
- Enter the password used at this time for the "Expert" access level. If it is the default password, enter "0058". Push [←] and then [>].
- Increase the value in menu item C.1.2 Tank Height. This value must be a minimum of 20% more than the true tank height.
- Go to a measurement page in Normal mode that shows the distance. Make a note of the distance of the reflection measured by the device.
- ➡ This is the delayed radar reflection. The distance shown will be the new tank height.
- Subtract the distance to the reflection from the true tank height.
- Go to menu item C1.11 Tank Bottom Offset (**Program Mode > Full Setup > Install. Parameters > Tank Bottom Offset**).
- Type in the difference you calculated as a negative value.
- ➡ A negative value will move the reference point above the tank bottom (as given in menu item C.1.2 Tank Height).
- Push [←], 2 × [▼] and [>] to go to C1.2 Tank Height.
- Type in the distance that was shown in Normal mode.
- Push 4 × [←] to exit to the "Save Configuration?" window.
- Select **Yes** and push [←].
- ➡ The device will go back to Normal mode.



INFORMATION!

For more data on menu items, refer to Function description on page 70 – table C: Full Setup.

6.4.8 How to make a filter to remove radar signal interference

If the device measures level in a tank that contains obstructions (agitator, supports, heating pipes etc.), these objects can cause radar signal interference (parasitic signals). You can use the empty spectrum function (menu A4.2) in the Quick Setup menu to make a filter to remove radar signal interference.



INFORMATION!

We recommend that you do an empty spectrum scan when the tank is empty and all the moving parts (agitators etc.) are in operation.

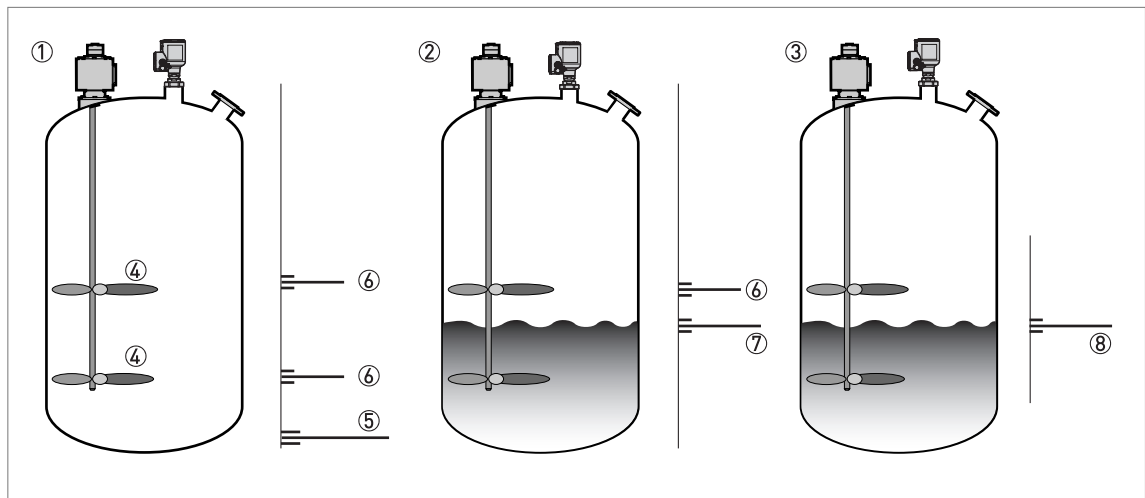

Figure 6-10: How to make a filter to remove radar signal interference

- ① Empty tank before the device uses the empty spectrum scan (with a graph of reflections shown)
- ② Partially filled tank before the device uses the empty spectrum scan (with a graph of reflections shown)
- ③ Partially filled tank after the device uses the empty spectrum scan (with a graph of reflections shown)
- ④ Agitator blades location Ladder
- ⑤ Tank bottom signal
- ⑥ Agitator blades signals (interference signals) before the device does the empty spectrum scan
- ⑦ Signal of the liquid before the device does the empty spectrum scan
- ⑧ Reflected signal if the device uses the data from the empty spectrum scan. The device only uses the reflection on the surface of the liquid to measure distance.



- After you enter Program mode, set the access level to "Expert". For more data about the procedure, refer to *Protection of the device settings (access levels)* on page 57.
- Push [▼], [>], [▼] and [>] to go to the menu item A4.2 Empty Spectrum.
- Push [>] to start the empty spectrum recording procedure. For more data, refer to *Empty spectrum recording* on page 92. Push [←] at the end of each step of the procedure to continue to the next step.



CAUTION!

If the "partial distance" value is more than the distance to the product surface, then the device will put the level signal through the filter and the device will not measure the level of the product correctly.



INFORMATION!

For more data on empty spectrum scans, refer to *Function description* on page 70— table A. Quick Setup menu (menu item A4.2).

6.5 Status messages and diagnostic data

Device status and error messages are shown on a device status page in Normal mode and in menu item "C7.3.1 Messages View" in Program mode. Messages shown agree with NAMUR Guidelines NE 107. The error messages for the device are divided into status groups, each with one status signal. There are 16 status groups with fixed status signals and 8 groups with status signals that can be changed. The status groups are also divided into 4 groups: Sensor, Electronics, Configuration and Process.

Each status message (or status signal) has a special symbol which agrees with the NAMUR Guidelines. This symbol is shown with the message.



INFORMATION!

The status group name and the status signal (F/S/M/C) are shown. For more data, refer to the table that follows.

Status messages (NAMUR NE 107)

Symbol	Letter	Message	Description and effect
	F	Failure	No measurement is possible.
	S	Out of specification	Measurements are available but they are not sufficiently accurate. Do a check.
	M	Maintenance required	Measurements continue to be accurate but this could change after a short time.
	C	Function check	A test function is on. The value shown does not agree with the correct measured value.
	I	Information	This status message does not have an effect on device measurements.

Normal mode: device status symbol

If the device status changes, the device shows a status symbol in the top left corner of the display screen in Normal mode:

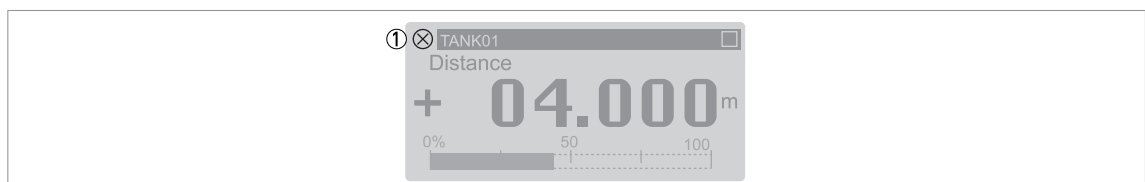

Figure 6-11: Device status: Normal mode

① Device status symbol (NAMUR NE 107)

Normal mode: device status messages

There is also a device status page in Normal mode. This page shows a list of short status messages and gives the status of the device at this time. Push the [▲] or [▼] button to get to the status device status page in Normal mode.

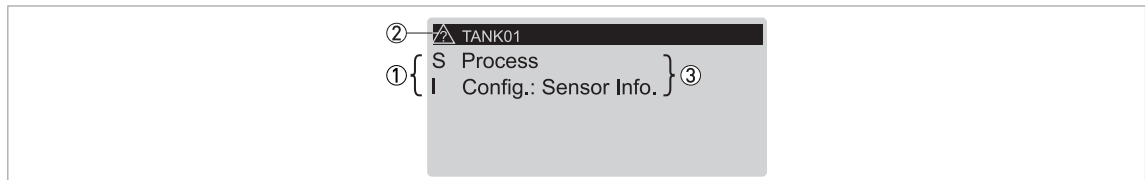

Figure 6-12: Device status: Normal mode – device status page

- ① Device status letter. Refer to the "Status messages" table at the start of this section.
- ② Device status symbol (NAMUR NE 107)
- ③ Short message about device status. For more data, refer to menu item "C7.3.1 Messages View" in Program mode.

Program mode: device status messages

Device status and error messages are shown in menu item "C7.3.1 Messages View" in Program mode. The top level of this menu item shows a list of short status messages.

Push the [▲] or [▼] button to make a selection from the list of status messages.

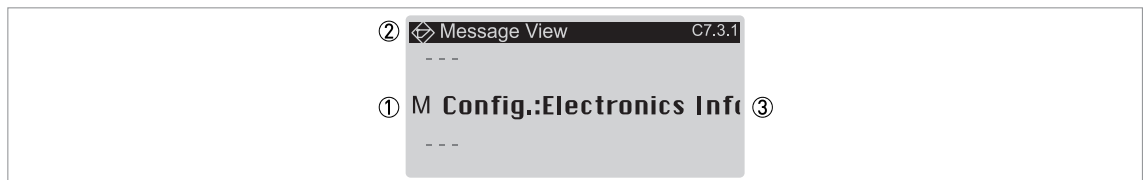

Figure 6-13: Device status and error messages (C7.3.1 Message View)

- ① Device status letter code (NAMUR NE 107). In this example, M = Maintenance required.
- ② Device status symbol (NAMUR NE 107)
- ③ Error message

Then push the [➤] button to show more data.

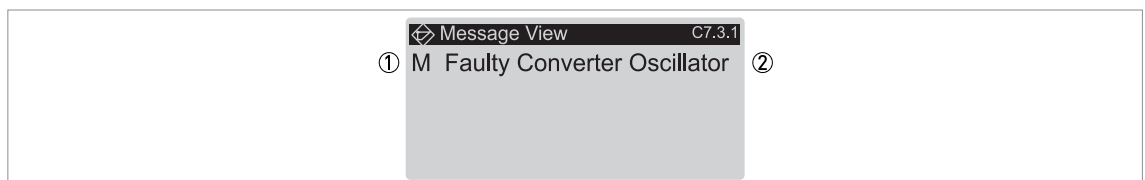

Figure 6-14: Description of the error (C7.3.1 Message View)

- ① Device status letter code (NAMUR NE 107). In this example, M = Maintenance required.
- ② Description of error

If the device shows an error message, refer to the table that follows for more data and to find a solution to a problem.

Description of errors and corrective actions

Status type	Error message	Description	Corrective action
F	Sensor		
	Corrupt Sensor Parameter	The sensor memory is bad.	De-energize and then energize the device again. If the message is shown again, tell the supplier.
	No Signal	There is no signal from the antenna or the antenna signal is too weak for a long time.	Do a check of the device installation. For more data about installation, refer to the handbook. If the message is shown again, tell the supplier.
	Microwave Tuning Voltage Error	A microwave error occurred.	De-energize and then energize the device again.
	Sensor Comm. Error	Internal bus communication error or hardware failure.	If the message is shown again, tell the supplier.
	No measurement value	The converter receives no measurement data for a long time.	Do a check of the device installation. For more data about installation, refer to the handbook. If the message is shown again, tell the supplier.
F	Electronics		
	Fatal Converter Error (DM) ①	An electronics or hardware failure occurred.	De-energize and then energize the device again.
	Fatal Converter Error (CO) ②	An electronics or hardware failure occurred.	If the message is shown again, tell the supplier.
	Fatal Converter Error (Generic)	An electronics or hardware failure occurred.	
	CO Safety Reaction ③	Current Output Safety Reaction. This error message is shown if the current output is less than 3.6 mA or more than 21 mA.	Do a check for other error messages.
	Internal Comm. Error	Internal bus communication error.	De-energize and then energize the device again. If the message is shown again, tell the supplier.
	Power Supply Error	Internal voltage is too low to energize the sensor.	Check the electrical connections to the power supply connection or replace the converter.
		Internal voltage is too high.	
	Sensor/Conv. FW Mismatch	The sensor firmware version does not agree with the converter firmware version. This can be caused by a bad firmware update.	De-energize and then energize the device again. If the message is shown again, tell the supplier.
	Max. Number of Restarts	The device could not start the measuring mode after a given number of times that the device was de-energized and then energized again.	Do a check of the power supply.
	Inconsistent Parameters	Internal bus communication error.	De-energize and then energize the device again. If the message is shown again, tell the supplier.
Sensor Comm. Error	Internal bus communication error or hardware failure.		

Status type	Error message	Description	Corrective action
F	Configuration		
	Inconsistent NVRAM	Incorrect data in the parameter memory.	De-energize and then energize the device again. If the message is shown again, tell the supplier.
	Incons. Converter Calib.	Incorrect calibration data in the converter module.	Tell the supplier.
	Incons. Sensor Calibration	Incorrect calibration data in the sensor module.	
	NVRAMs Mismatch	The serial number of the display screen does not agree with the serial number of the electronics module.	Make sure that the display screen agrees with the electronic module. Go to Full Setup > Device > Information and record the data in menu items C7.1.5 Electronic Revision and C7.1.6 Software Revision . If it is necessary, tell the supplier.
	Conv. NVRAM Layout Error	Incorrect data in the parameter memory.	De-energize and then energize the device again.
	Disp. NVRAM Layout Error	Incorrect data after an update of the firmware.	If the message is shown again, tell the supplier.
	CO Float Error ②	The device cannot use the measurement data because the device settings are incorrect.	You must make the device go back to its factory settings. Enter Program mode. Set the device to the "Expert" access level. Go to Full Setup > Device > Factory Default > Reset to Factory Default? and set this menu item to "Yes". Then go back to Normal mode and set the "Save Configuration?" page to "Yes". De-energize and then energize the device again. If the message is shown again, tell the supplier.
C	Electronics		
	FW Update	A firmware update of the converter module continues.	Wait for the firmware update to finish.

Status type	Error message	Description	Corrective action
C	Configuration		
	Sensor Sim. Active	The device simulates a measurement value that is set in menu item B1.1 Set Value . This measurement value can be a level, distance or reflection value. If you made a strapping table, the device can also simulate a volume or mass value.	Push "Enter" to stop the test.
	Current Out. Sim. Active	The device simulates a current output value that is set in menu item B1.2 Output . The current output test range is 3.6...21.5 mA.	Push "Enter" to stop the test.
	HART Sim. Active	The device simulates a measurement value. You can use the HART® interface of the device to simulate a measurement value.	Use the HART® interface to stop the test.
	LCO Simulation Active	The device simulates a current output value set in sub-menu B1 Simulation (distance, level, ullage volume, ullage mass, linearized distance, volume, mass or linearized level).	Push "Enter" to stop the test.
	SysMon Simulation Active	The system monitor sets the device to a simulated current output value.	Restart the device.
S	Sensor		
	Sensor Voltage Low	The voltage supplied to the sensor is too low.	Do a check of the power supply.
	Strong Signal	The signal amplitude is too large. It is possible that the signal is saturated.	Make sure that the device installation agrees with the data in the handbook. If the message is shown again, tell the supplier.
	Peak Lost (Level Lost)	No signal peak was found in the Search Window for a long time (>20 s).	Make sure that the device installation agrees with the data in the handbook. The antenna must be in the correct position and not installed above objects in the tank. If it is necessary, change the device settings and do a new empty spectrum recording. If the message is shown again, tell the supplier.
	Overfill	The signal peak is in the blocking distance (refer to menu item C1.5 Blocking Distance). There is a risk that the tank is too full.	Make sure that the device settings are correct and the process conditions are in the specified limits.
	Elec. Temp. Out Of Spec.	The temperature of the sensor is not in the specified limits.	Make sure that the device is operated in the permitted ambient temperature range.
S	Electronics		
	Elec. Temp. Out Of Spec.	The temperature of the converter is not in the specified limits.	Make sure that the device is operated in the permitted ambient temperature range.

Status type	Error message	Description	Corrective action
S	Process		
	CO Saturated Low ②	The measurement value is less than the minimum value of the current output range. The current output cannot go lower than its minimum value and thus does not agree with the correct measurement value.	Do a check of the process conditions and the minimum current output value.
	CO Saturated High ②	The measurement value is more than the maximum value of the current output range. The current output cannot go higher than its maximum value and thus does not agree with the correct measurement value.	Do a check of the process conditions and the maximum current output value.
M	Sensor		
	Weak Signal	The signal amplitude is too small.	Make sure that the device installation agrees with the data in the handbook. If the message is shown again, it is possible that a different antenna must be installed. tell the supplier.
	Bad Measurement Quality (Old Measurement)	The measurement value is incorrect and does not change for more than 10 s.	Make sure that the device installation agrees with the data in the handbook. If the message is shown again, tell the supplier.
	Empty Spectrum invalid	The empty spectrum recording does not agree with the process conditions at this time (e.g. the tank height was changed).	Do a new empty spectrum recording.

Status type	Error message	Description	Corrective action
M	Sensor Information		
	Failed Sensor MCU Test	The sensor electronics does a continuous self-test procedure. The test finds a fault.	De-energize and then energize the device again.
	Failed Sensor Input Test		If the message is shown again, tell the supplier.
	Bad Spectrum Quality	There is a large change in signal strength.	Make sure that the device installation agrees with the data in the handbook. If the message is shown again, we recommend that you attach a larger antenna to the device.
	Peak Lost in Tank Bottom	The signal was lost near the tank bottom. Spherical or conical tanks can cause the device to show this status message.	The device will measure the level of tank contents if you fill the tank. If the message is shown, tell the supplier.
	RC-Oscillator out of bounds	The sensor electronics does a continuous self-test procedure. The test finds a fault.	De-energize and then energize the device again.
	Sensor Reference out of range		If the message is shown again, tell the supplier.
	XCO out of bounds		
	Microwave Lock Error		
	Microwave Sweep Duration Error		
Microwave Supply Voltage Error			

① DM = data manager

② CO = current output

③ This error message is shown if the device is in SIL mode. CO = current output.

7.1 Periodic maintenance

7.1.1 General notes

In normal operational conditions, no maintenance is necessary. If it is necessary, maintenance must be done by approved personnel (the manufacturer or personnel approved by the manufacturer).



INFORMATION!

For more data about regular inspections and maintenance procedures for devices with Ex and other approvals, refer to the related supplementary instructions.

7.1.2 Maintenance of the O-rings for the housing covers

If the display cover ① or the terminal compartment cover ② of the housing is opened and closed, make sure that the O-rings are correctly greased or, if it is necessary, replaced. For more data about the replacement of the O-rings, refer to *Spare parts* on page 146.

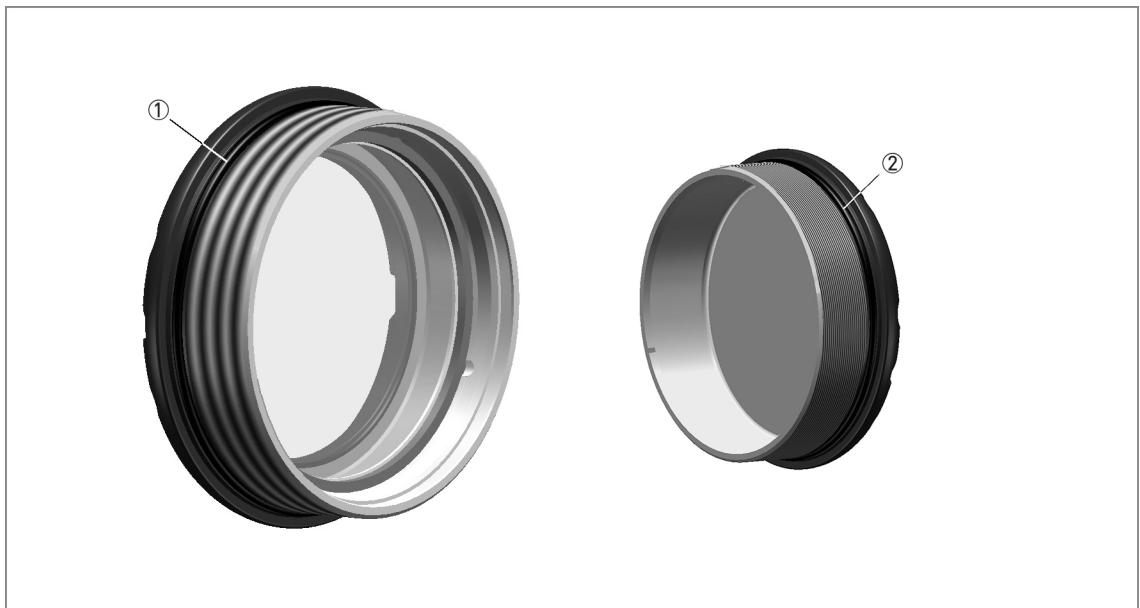

Figure 7-1: Maintenance of the O-rings

- ① Display cover
- ② Terminal compartment cover

**CAUTION!**

Use food-grade lubricant that agrees with good manufacturing practice at your production site. Make sure that the lubricant is applicable for the operating temperature range of the O-ring with the properties that follow:

- Operating temperature range of $-40...+130^{\circ}\text{C}$ / $-40...+266^{\circ}\text{F}$ without a negative effect on the lubrication of the O-ring
- Without silicone
- The bonding properties must be satisfactory
- Lithium-saponified
- Water-resistant
- Agrees with the O-ring material

7.1.3 How to clean the top surface of the device

**WARNING!**

Do not let more than 5 mm / 0.2" of dust collect on the top surface of the device. This is a possible source of ignition in a potentially explosive atmosphere.

**DANGER!**

Risk of electrostatic discharge from the gray plastic sun cover.

**Obey these instructions:**

- Keep the thread of the terminal compartment cover clean.
- If dirt collects on the device, clean it. Wipe the plastic sun cover with a damp cloth.

7.2 Service warranty

**WARNING!**

Only approved personnel can do an inspection of the device and repairs. If you find a problem, send the device back to your supplier for inspection and/or repairs.

**CAUTION!****Hygienic applications (devices with 3-A® approvals)**

If you see leakage from the leak detection port (refer to the illustration that follows), replace the antenna assembly and the gasket on the process connection to prevent contamination of the tank contents. Do a cleaning cycle before you start the system again.

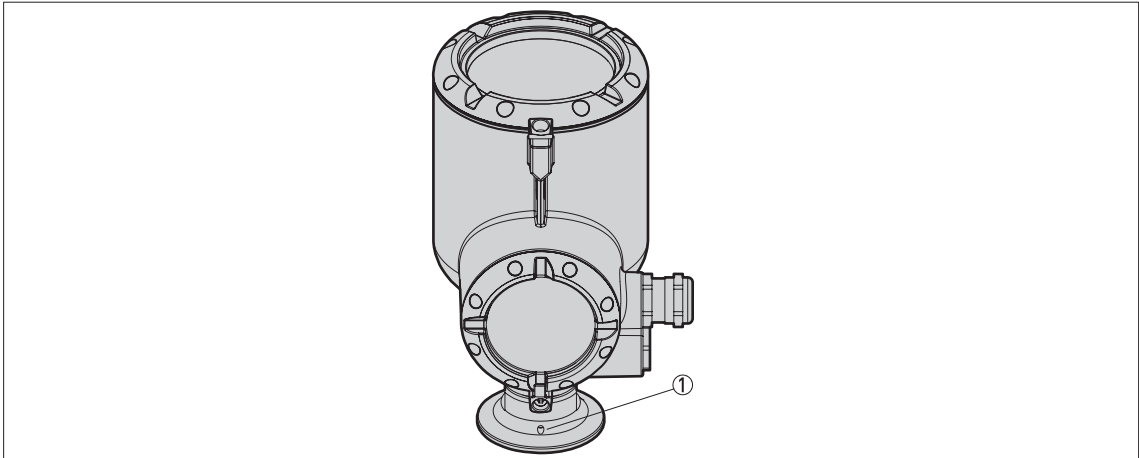

Figure 7-2: Leakage detection port for the Tri-Clamp® process connection

① Leakage detection port

Servicing by the customer is limited by warranty to:

- The removal and installation of the device.

For more data on how to prepare the device before you send it back, refer to *Returning the device to the manufacturer* on page 113.

7.3 Spare parts availability

The manufacturer adheres to the basic principle that functionally adequate spare parts for each device or each important accessory part will be kept available for a period of 3 years after delivery of the last production run for the device.

This regulation only applies to spare parts which are subject to wear and tear under normal operating conditions.

7.4 Availability of services

The manufacturer offers a range of services to support the customer after expiration of the warranty. These include repair, maintenance, technical support and training.



INFORMATION!

For more precise information, please contact your local sales office.

7.5 Returning the device to the manufacturer

7.5.1 General information

This device has been carefully manufactured and tested. If installed and operated in accordance with these operating instructions, it will rarely present any problems.



WARNING!

Should you nevertheless need to return a device for inspection or repair, please pay strict attention to the following points:

- *Due to statutory regulations on environmental protection and safeguarding the health and safety of the personnel, the manufacturer may only handle, test and repair returned devices that have been in contact with products without risk to personnel and environment.*
- *This means that the manufacturer can only service this device if it is accompanied by the following certificate (see next section) confirming that the device is safe to handle.*



WARNING!

If the device has been operated with toxic, caustic, radioactive, flammable or water-endangering products, you are kindly requested:

- *to check and ensure, if necessary by rinsing or neutralising, that all cavities are free from such dangerous substances,*
- *to enclose a certificate with the device confirming that it is safe to handle and stating the product used.*

7.5.2 Form (for copying) to accompany a returned device



CAUTION!

To avoid any risk for our service personnel, this form has to be accessible from outside of the packaging with the returned device.

Company:		Address:	
Department:		Name:	
Tel. no.:		Email address:	
Manufacturer's order no. or serial no.:			
The device has been operated with the following medium:			
This medium is:	<input type="checkbox"/>	radioactive	
	<input type="checkbox"/>	water-hazardous	
	<input type="checkbox"/>	toxic	
	<input type="checkbox"/>	caustic	
	<input type="checkbox"/>	flammable	
	<input type="checkbox"/>	We checked that all cavities in the device are free from such substances.	
	<input type="checkbox"/>	We have flushed out and neutralized all cavities in the device.	
We hereby confirm that there is no risk to persons or the environment through any residual media contained in the device when it is returned.			
Date:		Signature:	
Stamp:			

7.6 Disposal



LEGAL NOTICE!

Disposal must be carried out in accordance with legislation applicable in your country.

Separate collection of WEEE (Waste Electrical and Electronic Equipment) in the European Union:



According to the directive 2012/19/EU, the monitoring and control instruments marked with the WEEE symbol and reaching their end-of-life **must not be disposed of with other waste**.

The user must dispose of the WEEE to a designated collection point for the recycling of WEEE or send them back to our local organisation or authorised representative.

8.1 Measuring principle

A radar signal is emitted via an antenna, reflected from the product surface and received after a time t . The radar principle used is FMCW (Frequency Modulated Continuous Wave).

The FMCW-radar transmits a high frequency signal whose frequency increases linearly during the measurement phase (called the frequency sweep). The signal is emitted, reflected on the measuring surface and received with a time delay, t . Delay time, $t=2d/c$, where d is the distance to the product surface and c is the speed of light in the gas above the product.

For further signal processing the difference Δf is calculated from the actual transmitted frequency and the received frequency. The difference is directly proportional to the distance. A large frequency difference corresponds to a large distance and vice versa. The frequency difference Δf is transformed via a Fast Fourier Transform (FFT) into a frequency spectrum and then the distance is calculated from the spectrum. The level results from the difference between the tank height and the measured distance.

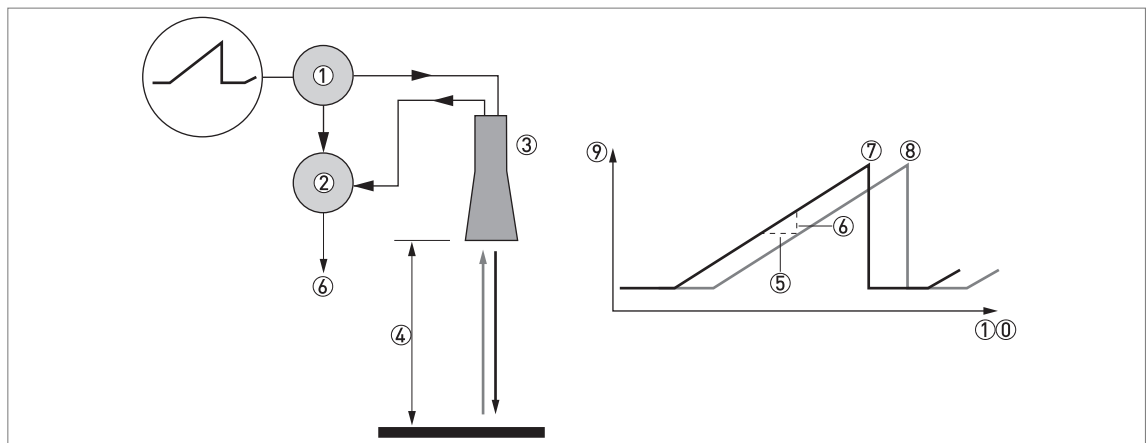

Figure 8-1: Measuring principle of FMCW radar

- ① Transmitter
- ② Mixer
- ③ Antenna
- ④ Distance to product surface, where change in frequency is proportional to distance
- ⑤ Differential time delay, Δt
- ⑥ Differential frequency, Δf
- ⑦ Frequency transmitted
- ⑧ Frequency received
- ⑨ Frequency
- ⑩ Time

Measurement modes

"Direct" mode

If the dielectric constant of the liquid is high ($\epsilon_r \geq 1.4$), the level signal is the reflection on the surface of the liquid.

"TBF Auto" mode

If the dielectric constant of the liquid is low (ϵ_r 1.4...1.5, for long-distance measurement), you must use "TBF Auto" mode to measure level correctly. "TBF Auto" is an automatic mode that lets the device make a selection between "Direct" mode and "TBF" mode. If the device finds a large radar reflection above the "tank bottom area" (the bottom 20% of the tank height), the device will use "Direct" mode. If the device finds a large radar reflection in the "tank bottom area", the device uses TBF mode. This mode can be used only in tanks with flat bottoms or in stilling wells with a reference plate at the bottom.

"Full TBF" mode

TBF = Tank Bottom Following. If the dielectric constant of the liquid is very low ($\epsilon_r < 1.4$), you must use "TBF Full" mode to measure level correctly. The device uses the radar reflection on the bottom of the tank (the signal goes through the liquid). This mode can be used only in tanks with flat bottoms or in stilling wells with a reference plate at the bottom.



CAUTION!

"TBF FULL" AND "TBF AUTO" MODES

It is important to enter the correct dielectric constant value in menu item C2.2 Epsilon R Product. If this value is incorrect, the device will not measure level accurately.

8.2 Technical data



INFORMATION!

- The following data is provided for general applications. If you require data that is more relevant to your specific application, please contact us or your local sales office.
- Additional information (certificates, special tools, software,...) and complete product documentation can be downloaded free of charge from the website.

Measuring system

Measuring principle	2-wire loop-powered level transmitter; FMCW radar
Frequency range	W-band (78...82 GHz)
Max. radiated power (EIRP)	< -41.3 dBm according to ETSI EN 302 372 (TLPR) and ETSI EN 302 729 (LPR)
Application range	Level measurement of liquids, pastes and slurries in hygienic applications
Primary measured value	Distance and reflection
Secondary measured value	Level, volume and mass

Design

Construction	The measurement system consists of a measuring sensor (antenna) and a signal converter
Options	Integrated LCD display (-20...+70°C / -4...+158°F); if the ambient temperature is not in these limits, then this condition can stop the display
	Weather protection
Max. measuring range (antenna)	Lens, DN25 (1"): 25 m / 82 ft
	Lens, DN40 (1½"): 50 m / 164 ft
	Refer also to "Measuring accuracy" on page 122
Min. tank height	0.2 m / 8"
Recommended minimum blocking distance	Lens, DN25 (1"): 0.1 m / 4"
	Lens, DN40 (1½"): 0.2 m / 8"
Min. distance for reflection measurement	1 m / 3.3 ft
Beam angle (antenna)	Lens, DN25 (1"): 10°
	Lens, DN40 (1½"): 8°
Display and user interface	
Display	Backlit LCD display
	128 × 64 pixels in 64-step greyscale with 4-button keypad
Interface languages	English, French, German, Italian, Spanish, Portuguese, Chinese (simplified), Japanese, Russian, Czech, Polish and Turkish

Measuring accuracy

Resolution	1 mm / 0.04"
Repeatability	±1 mm / ±0.04"
Accuracy	±2 mm / ±0.08", when distance ≤ 10 m / 33 ft; ±0.02% of measured distance, when distance > 10 m / 33 ft. For more data, refer to <i>Measuring accuracy</i> on page 122.
Digital temperature drift	Max. ±10 mm / ±0.39" for the full temperature range

Reference conditions acc. to EN 61298-1	
Temperature	+15...+25°C / +59...+77°F
Pressure	1013 mbara ±50 mbar / 14.69 psia ±0.73 psi
Relative air humidity	60% ±15%
Target	Metal plate in an anechoic chamber

Operating conditions

Temperature	
Ambient temperature	-40...+80°C / -40...+176°F Integrated LCD display: -20...+70°C / -5...+140°F; if the ambient temperature is not in these limits, the display switches off. The device continues to operate correctly. Ex: see supplementary operating instructions or approval certificates.
Relative humidity	0...99%
Storage temperature	-40...+85°C / -40...+185°F
Process connection temperature (higher temperature on request)	-40...+150°C / -40...+302°F (the process connection temperature must agree with the temperature limits of the gasket material. Refer to "Materials" in this table.) Ex: see supplementary operating instructions or approval certificates
Pressure	
Process pressure	DN25 (1") Lens antenna with DN50 VARIVENT® Type N connection -1...10 barg / -14.5...145 psig
	DN25 (1") Lens antenna and DN40 (1½") Lens antenna with all process connections except the DN50 VARIVENT® Type N -1...25 barg / -14.5...363 psig
Other conditions	
Dielectric constant (ϵ_r)	Direct mode: ≥ 1.4 TBF mode: ≥ 1.1
Ingress protection	IEC 60529: IP66 / IP68 (0.1 barg / 1.45 psig)
	NEMA 250: NEMA type 4X - 6 (housing) and type 6P (antenna)
Maximum rate of change	60 m/min / 196 ft/min

Installation conditions

Process connection position	Make sure that there are not any obstructions directly below the process connection for the device. For more data, refer to <i>Installation</i> on page 21.
Dimensions and weights	For dimensions and weights data refer to <i>Dimensions and weights</i> on page 126.

Materials

Housing	Standard: Polyester-coated aluminium
	Option: Stainless steel (1.4404 / 316L) – non-Ex devices only. Ex approvals will be available in the second quarter of 2018.
Wetted materials	PEEK Victrex 450G and stainless steel (1.4404 / 316L)
Surface roughness of wetted parts	Ra < 0.8 µm / 32 µin – AARH
Gaskets	BioControl®: EPDM (-20°C...+150°C / -4...+302°F) SMS, Tri-Clamp®, VARIVENT®, DIN 11851, DIN 11864-1: without ①
Cable gland	Standard: none
	Options: Plastic (Non-Ex: black, Ex i-approved: blue); nickel-plated brass; stainless steel; M12 (4-pin connector)
Weather protection (Option)	Stainless steel (1.4404 / 316L)

Process connections

For DN25/1" Lens antenna	Tri-Clamp® 1½" or 2"; DIN 11851 DN40 or DN50; DIN 11864-1 DN40 or DN50; SMS 51; VARIVENT® Type N (DN50); others on request
For DN40/1½" Lens antenna	BioControl® DN50; Tri-Clamp® 2"; others on request

Electrical connections

Power supply	Terminals output – Non-Ex / Ex i: 12...30 V DC; min./max. value for an output of 21.5 mA at the terminals
	Terminals output – Ex d: 16...36 V DC; min./max. value for an output of 21.5 mA at the terminals
Maximum current	21.5 mA
Current output load	Non-Ex / Ex i: $R_L [\Omega] \leq ((U_{ext} - 12 \text{ V})/21.5 \text{ mA})$. For more data, refer to <i>Minimum power supply voltage</i> on page 124.
	Ex d: $R_L [\Omega] \leq ((U_{ext} - 16 \text{ V})/21.5 \text{ mA})$. For more data, refer to <i>Minimum power supply voltage</i> on page 124.
Cable entry	Standard: M20×1.5; Options: ½ NPT; 4-pin male M12 connector
Cable gland	Standard: none
	Options: M20×1.5 (cable diameter: 7...12 mm / 0.28...0.47"); others are available on request
Cable entry capacity (terminal)	0.5...3.31 mm ² (AWG 20...12)

Input and output

Current output	
Output signal	Standard: 4...20 mA
	Options: 3.8...20.5 mA acc. to NAMUR NE 43; 4...20 mA (reversed); 3.8...20.5 mA (reversed) acc. to NAMUR NE 43
Output type	Passive
Resolution	±5 µA
Temperature drift	Typically 50 ppm/K
Error signal	High: 21.5 mA; Low: 3.5 mA acc. to NAMUR NE 43
HART®	
Description	Digital signal transmitted with the current output signal (HART® protocol) ②
Version	7.4
Load	≥ 250 Ω
Digital temperature drift	Max. ±15 mm / 0.6" for the full temperature range
Multi-drop operation	Yes. Current output = 4 mA. Enter Program mode to change the polling address (1...63).
Available drivers	FC475, AMS, PDM, FDT/DTM
PROFIBUS PA (pending)	
Type	PROFIBUS MBP interface that agrees with IEC 61158-2 with 31.25 kbit/s; voltage mode (MBP = Manchester-Coded, Bus-Powered)
Function blocks	1 × Transducer Block Level (TB-Level), 1 × Physical Block (PB), 4 × Analog Input Block (AI), 1 × Totalizer Function Block (TOT)
Device power supply	9...32 V DC – bus powered; no additional power supply required
Polarity sensitivity	No
Basic current	18 mA

Approvals and certification

CE	The device meets the essential requirements of the EU Directives. The manufacturer certifies successful testing of the product by applying the CE marking.
	For more data about the EU Directives and European Standards related to this device, refer to the EU Declaration of Conformity. You can download this document free of charge from the website.
Conformity to sanitary regulations	Regulation (EC) No 1935/2004, Commission Regulation (EC) No 2023/2006, Commission Regulation (EU) No 10/2011
	FDA 21 CFR 177.2600 and CFR 177.2415
Vibration resistance	EN 60068-2,64 and EN 60721-3-4 (1...9 Hz: 3 mm / 10...200 Hz:1g; 10g shock ½ sinus: 11 ms)
Explosion protection	
ATEX (EU Type Approval) - pending	II 1/2 G Ex ia IIC T6...T3 Ga/Gb;
	II 1/2 D Ex ia IIIC T85°C...T150°C Da/Db;
	II 1/2 G Ex db ia IIC T6...T3 Ga/Gb;
	II 1/2 D Ex ia tb IIIC T85°C...T150°C Da/Db
cQPSus - pending	Division ratings
	XP-IS, Class I, Div 1, GPS ABCD, T6...T3;
	DIP, Class II, III, Div 1, GPS EFG, T85°C...T150°C;
	IS, Class I, Div 1, GPS ABCD, T6...T3;
	IS, Class II, III, Div 1, GPS EFG, T85°C...T150°C;
	NI, Class I, Div 2, GPS ABCD, T6...T3;
	NI, Class II, III, Div 2, GPS FG, T85°C...T150°C
	Zone ratings
	Class I, Zone 1, AEx db ia [ia Ga] IIC T6...T3 Gb (US) – antenna suitable for Zone 0; Ex db ia [ia Ga] IIC T6...T3 Gb (Canada) – antenna suitable for Zone 0;
	Class I, Zone 0, AEx ia IIC T6...T3 Ga (US); Ex ia IIC T6...T3 Ga (Canada);
Zone 20, AEx ia IIIC T85°C...T150°C Da (US); Ex ia IIIC T85°C...T150°C Da (Canada);	
Zone 21, AEx ia tb [ia Da] IIIC T85°C...T150°C Db (US) – antenna suitable for Zone 20; Ex ia tb [ia Da] IIIC T85°C...T150°C Db (Canada) – antenna suitable for Zone 20	
Hygienic	
3-A®	For Tri-Clamp®
EHEDG	For VARIVENT® Type N, Tri-Clamp®, DIN 11851 and DIN 11864-1 when fitted with an alternative gasket (which agrees with EHEDG Position paper "Easy cleanable pipe couplings and process connections" Version 3, December 2015).
Other standards and approvals	
Electromagnetic compatibility	EU: Electromagnetic Compatibility directive (EMC)
Radio approvals	EU: Radio Equipment directive (RED)
	FCC Rules: Part 15
	Industry Canada: RSS-211
Electrical safety	EU: Agrees with the safety part of the Low Voltage directive (LVD)
	USA and Canada: Agrees with NEC and CEC requirements for installation in ordinary locations

NAMUR	NAMUR NE 21 Electromagnetic Compatibility (EMC) of Industrial Process and Laboratory Control Equipment
	NAMUR NE 43 Standardization of the Signal Level for the Failure Information of Digital Transmitters
	NAMUR NE 53 Software and Hardware of Field Devices and Signal Processing Devices with Digital Electronics
	NAMUR NE 107 Self-Monitoring and Diagnosis of Field Devices

① Tri-Clamp® is a registered trademark of Ladish Co., Inc.. BioControl® is a registered trademark of Neumo-Ehrenberg-Group.
VARIVENT® is a registered trademark of GEA Tuchenhausen GmbH.

② HART® is a registered trademark of the HART Communication Foundation

8.3 Measuring accuracy

Use these graphs to find the measuring accuracy for a given distance from the transmitter.

DN25 (1") Lens antenna

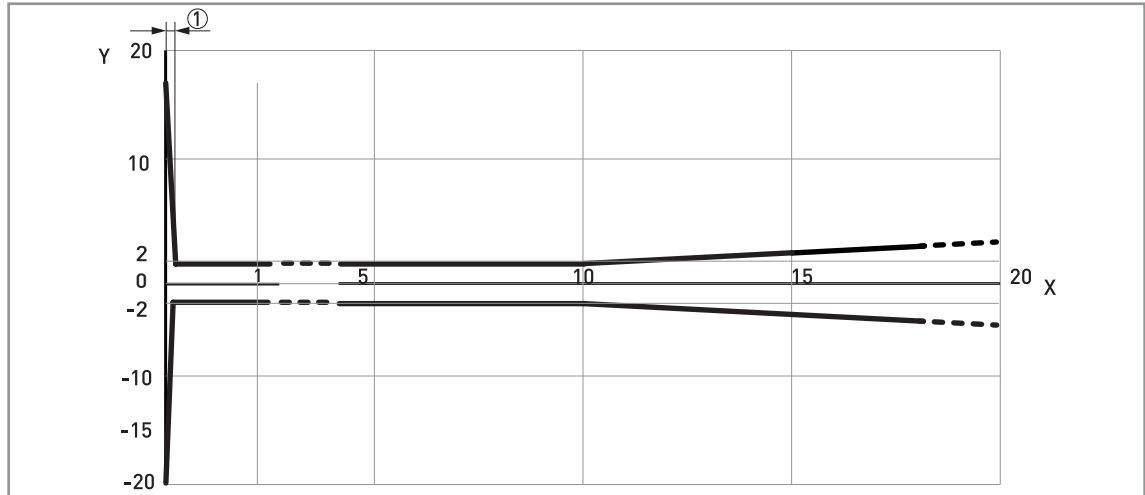

Figure 8-2: DN25 (1") Lens antenna: measuring accuracy (graph of measuring accuracy in mm against measuring distance in m)

X: Measuring distance from the thread stop or flange facing of the process connection [m]

Y: Measuring accuracy [+yy mm / -yy mm]

① 100 mm

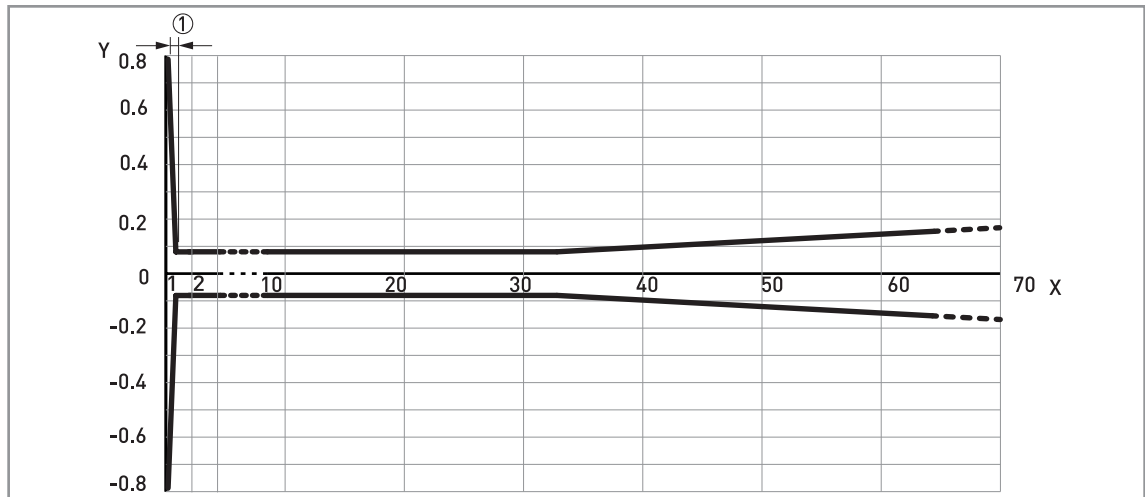

Figure 8-3: DN25 (1") Lens antenna: measuring accuracy (graph of measuring accuracy in inches against measuring distance in ft)

X: Measuring distance from the thread stop or flange facing of the process connection [ft]

Y: Measuring accuracy [+yy inches / -yy inches]

① 3.94"



INFORMATION!

To calculate the accuracy at a given distance from the antenna, refer to Technical data on page 117(measuring accuracy).

DN40 (1½") Lens antenna

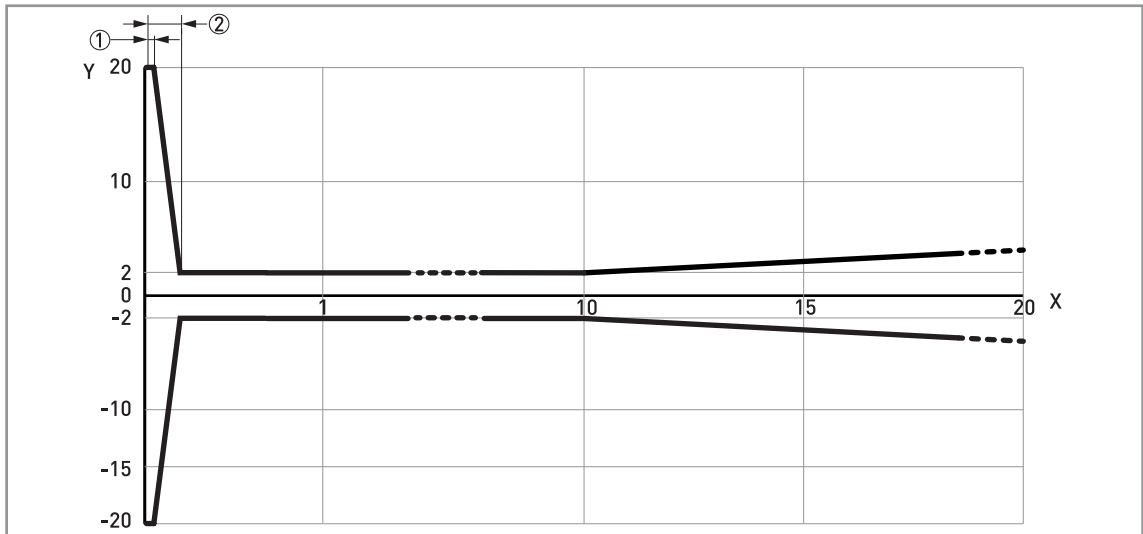

Figure 8-4: DN40 (1½") Lens antenna: measuring accuracy (graph of measuring accuracy in mm against measuring distance in m)

X: Measuring distance from the thread stop or flange facing of the process connection [m]

Y: Measuring accuracy [+yy mm / -yy mm]

① 50 mm

② 200 mm

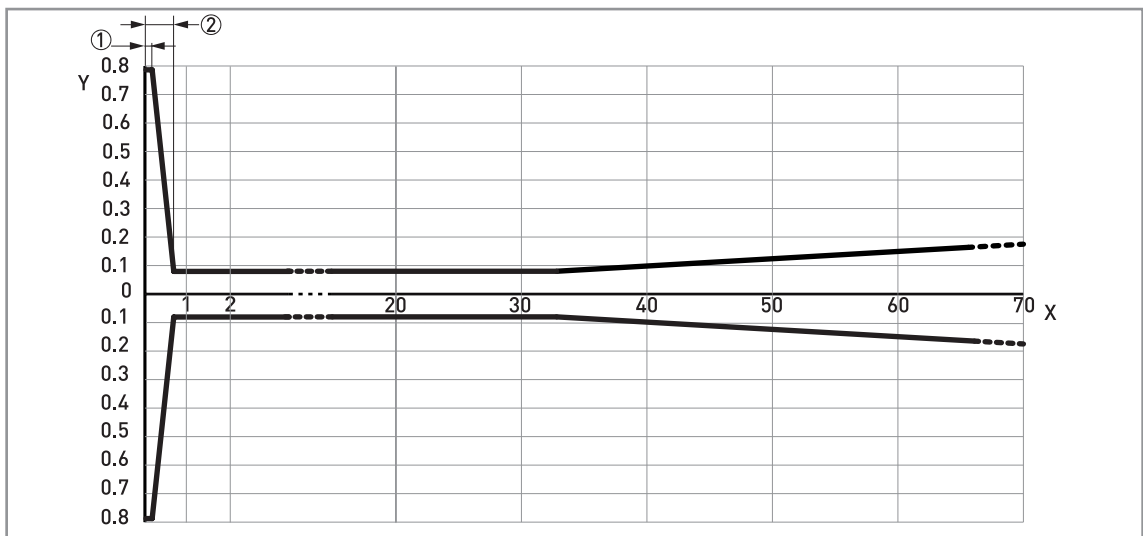

Figure 8-5: DN40 (1½") Lens antenna: measuring accuracy (graph of measuring accuracy in inches against measuring distance in ft)

X: Measuring distance from the thread stop or flange facing of the process connection [ft]

Y: Measuring accuracy [+yy inches / -yy inches]

① 1.97"

② 7.87"



INFORMATION!

To calculate the accuracy at a given distance from the antenna, refer to Technical data on page 117 (measuring accuracy).

8.4 Minimum power supply voltage

Use these graphs to find the minimum power supply voltage for a given current output load.

Non-Ex and Hazardous Location approved (Ex i / IS) devices

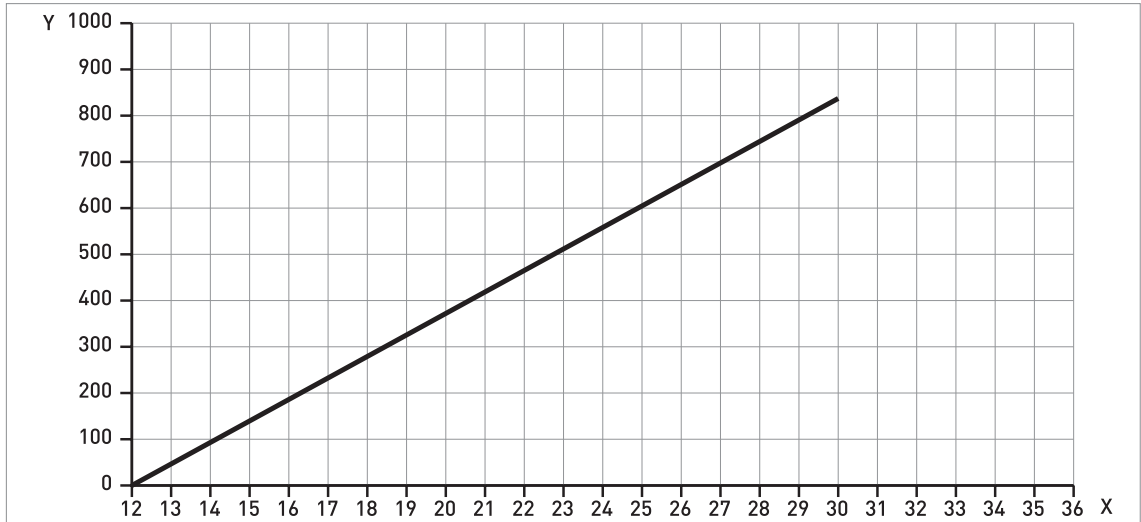

Figure 8-6: Minimum power supply voltage for an output of 21.5 mA at the terminals (Non-Ex and Hazardous Location approval (Ex i / IS))

X: Power supply U [V DC]
 Y: Current output load R_L [Ω]

Hazardous Location (Ex d / XP/NI) approved devices

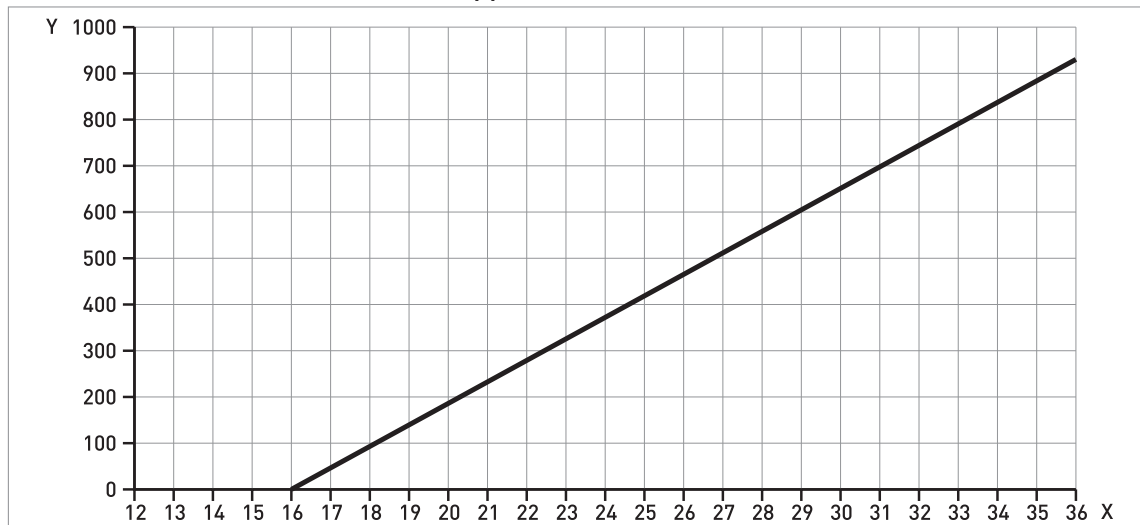

Figure 8-7: Minimum power supply voltage for an output of 21.5 mA at the terminals (Hazardous Location approval [Ex d / XP/NI])

X: Power supply U [V DC]

Y: Current output load R_L [Ω]

8.5 Dimensions and weights

DN25 / 1" Lens antenna versions

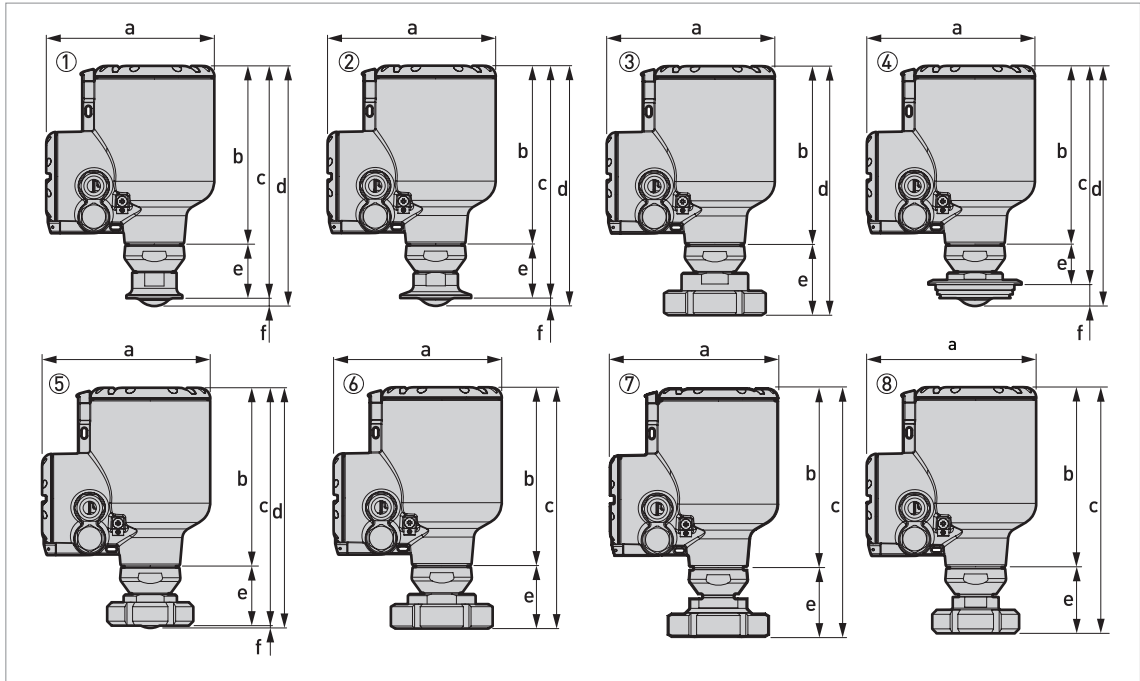

Figure 8-8: DN25 / 1" Lens antenna versions

- ① DN25 / 1" Lens antenna with 1½" Tri-Clamp® connection
- ② DN25 / 1" Lens antenna with 2" Tri-Clamp® connection
- ③ DN25 / 1" Lens antenna with SMS 1145 (51) connection
- ④ DN25 / 1" Lens antenna with VARIVENT® connection
- ⑤ DN25 / 1" Lens antenna with DN40 DIN 11851 connection
- ⑥ DN25 / 1" Lens antenna with DN50 DIN 11851 connection
- ⑦ DN25 / 1" Lens antenna with DN50 DIN 11864-1 connection
- ⑧ DN25 / 1" Lens antenna with DN40 DIN 11864-1 connection

**INFORMATION!**

- The diameter of the outer sheath of the cable must be 7...12 mm or 0.28...0.47".
- Cable glands for cQPSus-approved devices must be supplied by the customer.
- A weather protection cover is available as an accessory with all devices.

DN25 / 1" Lens antenna: Dimensions in mm

Type of process connection	Dimensions [mm]					
	a	b	c	d	e	f
1½" Tri-Clamp®	151	160	209	216	48.7	7
2" Tri-Clamp®	151	160	209	216	48.7	11
SMS 1145	151	160	224	—	63.4	—
VARIVENT®	151	160	209	216	48.6	7
DN40 DIN 11851	151	160	214	216	53.6	2.1
DN50 DIN 11851	151	160	217	—	56.7	—
DN50 DIN 11864-1	151	160	222.8	—	62.5	—
DN40 DIN 11864-1	151	160	219.8	—	59.4	—

DN25 / 1" Lens antenna: Dimensions in inches

Type of process connection	Dimensions [inches]					
	a	b	c	d	e	f
1½" Tri-Clamp®	5.94	6.30	8.23	8.50	1.92	0.28
2" Tri-Clamp®	5.94	6.30	8.23	8.50	1.92	0.43
SMS 1145	5.94	6.30	8.82	—	2.50	—
VARIVENT®	5.94	6.30	8.23	8.50	1.91	0.28
DN40 DIN 11851	5.94	6.30	8.43	8.50	2.11	0.08
DN50 DIN 11851	5.94	6.30	8.54	—	2.23	—
DN50 DIN 11864-1	5.94	6.30	8.77	—	2.46	—
DN40 DIN 11864-1	5.94	6.30	8.65	—	2.34	—

DN40 / 1½" Lens antenna versions

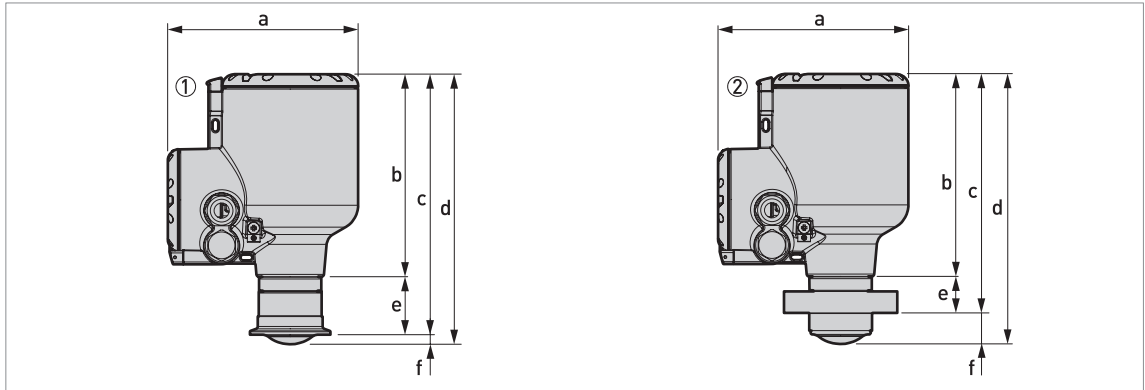

Figure 8-9: DN40 / 1½" Lens antenna versions

- ① DN40 / 1½" Lens antenna with 2" Tri-Clamp® connection
- ② DN40 / 1½" Lens antenna with DN50 NEUMO BioControl® connection



INFORMATION!

- The diameter of the outer sheath of the cable must be 7...12 mm or 0.28...0.47".
- Cable glands for cQPSus-approved devices must be supplied by the customer.
- A weather protection cover is available as an accessory with all devices.

DN40 / 1" Lens antenna: Dimensions in mm

Type of process connection	Dimensions [mm]					
	a	b	c	d	e	f
2" Tri-Clamp®	151	160	209	216	48.7	11
DN50 NEUMO BioControl®	151	160	189.3	213.8	28.9	24.6

DN40 / 1" Lens antenna: Dimensions in inches

Type of process connection	Dimensions [inches]					
	a	b	c	d	e	f
2" Tri-Clamp®	5.94	6.30	8.23	8.50	1.92	0.43
DN50 NEUMO BioControl®	5.94	6.30	7.45	8.41	1.14	0.97

Weather protection option

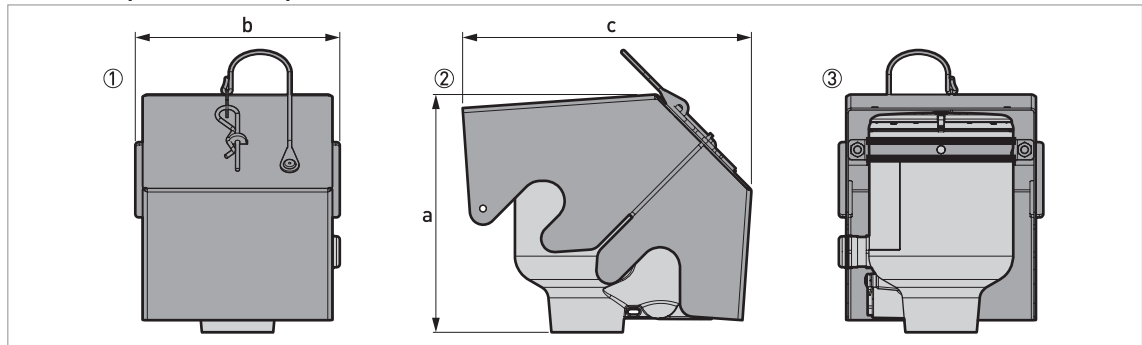

Figure 8-10: Weather protection option

- ① Front view (with weather protection closed)
- ② Left side (with weather protection closed)
- ③ Rear view (with weather protection closed)

Weather protection: Dimensions and weights

	Dimensions						Weights [kg]	
	a		b		c		[kg]	[lb]
	[mm]	[inch]	[mm]	[inch]	[mm]	[inch]		
Weather protection	177	6.97	153	6.02	216	8.50	1.3	2.9

Converter weight

Type of housing	Weights	
	[kg]	[lb]
Compact aluminium housing	2.1	4.6
Compact stainless steel housing	4.5	9.9

Antenna option weights

Antenna options	Min./Max. weights	
	[kg]	[lb]

Standard options, with converter

DN25 (1") Lens antenna with 1.5" Tri-Clamp® connection	2.8	6.2
DN25 (1") Lens antenna with 2" Tri-Clamp® connection	2.8	6.2
DN25 (1") Lens antenna with DN40 DIN11851 connection	2.9	6.4
DN25 (1") Lens antenna with DN50 DIN11851 connection	3.2	7.1
DN25 (1") Lens antenna with DN51 SMS1145 connection	3.2	7.1
DN25 (1") Lens antenna with DN50 VARIVENT® Type N connection	2.9	6.4
DN25 (1") Lens antenna with DN40 DIN11864-1 connection	2.9	6.4
DN25 (1") Lens antenna with DN50 DIN11864-1 connection	3.2	7.1
DN40 (1½") Lens antenna with DN50 NEUMO BioControl® connection	2.9	6.4
DN40 (1½") Lens antenna with 2" Tri-Clamp® connection	2.4	5.3

9.1 General description

The HART® Protocol is an open digital communication protocol for industry. It is free to use by anyone. It is included in the software embedded in signal converters of HART-compatible devices.

There are 2 classes of devices which support the HART® Protocol: operating devices and field devices. There are 2 classes of operating devices (Master): PC-supported workstations (Primary Master) and manual control units (Secondary Master). These can be used in control centres and other locations. HART® field devices include sensors, converters and actuators. Field devices include 2-wire and 4-wire devices, and also intrinsically-safe versions for use in hazardous areas.

There are 2 primary operation modes for HART-compatible devices: point-to-point mode and multi-drop mode.

If the device is used in point-to-point mode, the HART® Protocol uses the Bell 202 Frequency Shift Keying (FSK) standard to put a digital signal on top of the 4...20 mA signal. The connected device sends and receives digital signals that agree with the HART® Protocol, and sends analog signals at the same time. Only 1 device can be connected to the signal cable.

If the device is used in multi-drop mode, the network only uses a digital signal that agrees with the HART® Protocol. The loop current is set to 4 mA. You can connect a maximum of 63 devices to the signal cable.

An FSK or HART® modem is included in field devices and manual control units. It is necessary to have an external modem for PC-supported workstations. The external modem is connected to the serial or USB interface.

9.2 Software history



INFORMATION!

In the table below, "x" is a placeholder for possible multi-digit alphanumeric combinations, depending on the available version.

Release date	Devices	HART®	
		Device Revision	DD Revision
2016-04	All revisions	1	1

HART® identification codes and revision numbers

Manufacturer ID:	69 (0x45)
Expanded Device Type:	0x45b9
Device Revision:	1
DD Revision	1
DD Version (NAMUR)	01.11
HART® Universal Revision:	7.4
FC 475 system SW.Rev.:	≥ 3.7
AMS version:	≥ 11.1
PDM version:	≥ 6.0
FDT version:	≥ 1.2

9.3 Connection variants

The signal converter is a 2-wire device with 4...20 mA current output and HART® interface.

- **Multi-Drop Mode is supported**
In a Multi-Drop communication system, more than 1 device is connected to a common transmission cable.
- **Burst Mode is not supported**

There are two ways of using the HART® communication:

- as Point-to-Point connection and
- as Multi-Drop connection with 2-wire connection.

9.3.1 Point-to-Point connection – analogue / digital mode

Point-to-Point connection between the signal converter and the HART® Master.

The current output of the device is passive.

Also refer to *Point-to-point connection* on page 45.

9.3.2 Multi-Drop connection (2-wire connection)

Up to 63 devices may be installed in parallel (this signal converter and other HART® devices).

For an illustration of multi-drop networks, refer to *Multi-drop networks* on page 46.

For data on communication in multi-drop mode, refer to *HART® network configuration* on page 94.

9.4 HART® device variables

HART® device variable	Code	Type
sensor value	0	linear
level	1	linear
distance	2	linear
reflection	3	linear
level linearization ①	4	linear
volume conversion ②	5	linear
mass conversion ②	6	linear
distance linearization ①	7	linear
ullage volume conversion ②	8	linear
ullage mass conversion ②	9	linear

① This HART® device variable is available if you created a linearization table in the conversion menu

② This HART® device variable is available if you created a strapping table in the conversion menu

The HART® dynamic variables PV (Primary Variable), SV (Secondary Variable), TV (Third Variable) and QV (Fourth Variable) can be assigned to any of the device variables.

The HART® dynamic variable PV is always connected to the HART® current output which is, for example, assigned to level measurement.

9.5 Field Communicator 475 (FC 475)

The Field Communicator is a hand terminal from Emerson Process Management that is designed to configure HART® and Foundation Fieldbus devices. Device Descriptions (DDs) are used to integrate different devices into the Field Communicator.

9.5.1 Installation



CAUTION!

The Field Communicator cannot be used to correctly configure, operate or read data from the device unless the Device Description (DD) file is installed.

System and software requirements for the Field Communicator

- System card that includes the "Easy Upgrade Option"
- Field Communicator Easy Upgrade Programming Utility
- HART® Device Description file

For more data, refer to the Field Communicator User's Manual.

9.5.2 Operation

**INFORMATION!**

The Field Communicator will not give you access to the service menu. A simulation is only possible for current outputs.

The Field Communicator and the device's local display use almost the same procedures to operate the signal converter. The online help for each menu item refers to the function number given to each menu item on the local device display. Protection of settings is the same as on the device's local display.

The Field Communicator always saves a complete configuration for communication with AMS.

9.6 Asset Management Solutions (AMS®)

The Asset Management Solutions Device Manager (AMS®) is a PC program from Emerson Process Management which is designed to configure and manage HART®, PROFIBUS and Foundation Fieldbus devices. Device Descriptions (DDs) are used to integrate different devices into the AMS®.

9.6.1 Installation

Please read the README.txt file in the Installation Kit.

If the Device Description has not been installed at this time, install the Installation Kit HART® AMS. You can download this .exe file from our website.

For installation data, refer to the "AMS Intelligent Device Manager Books Online" section "Basic AMS Functionality > Device Configurations > Installing Device Types > Procedures > Install device types from media".

9.6.2 Operation

**INFORMATION!**

For more data, refer to HART® menu tree for AMS on page 135.

9.6.3 Parameter for the basic configuration

Due to AMS requirements and conventions, there are differences when operating the signal converter with AMS and operating using the local keyboard. The service menu parameters are not supported and simulation is only possible for current outputs. The online help for each parameter contains its function number as a reference to the local device display.

9.7 Field Device Tool / Device Type Manager (FDT / DTM)

A Field Device Tool Container (FDT Container) is a PC program used to configure HART®, PROFIBUS and FOUNDATION™ fieldbus devices. To configure a device, an FDT container uses the applicable Device Type Manager (DTM).

9.7.1 Installation

Before you operate the device, the Device Type Manager (Device DTM) must be installed in the Field Device Tool Container. You can download this .msi file from our website. For installation and configuration data, refer to the documentation that is supplied with the Device DTM in the "Downloads" section of the website.

9.7.2 Operation

The DTM and the device's local display use almost the same procedures to operate the signal converter. For more data, refer to *Operation* on page 53.

9.8 Process Device Manager (PDM)

The Process Device Manager (PDM) is a Siemens PC program designed to configure HART® and PROFIBUS devices. Device Descriptions (DDs) are used to integrate different devices into the PDM.

9.8.1 Installation

Install Device Description files supplied in the Device Install HART® PDM folder. This is necessary for each type of field device that is used with SIMATIC PDM. This folder is available for download from the website.

If you use PDM version 5.2, refer to PDM manual, section 11.1 - Install device / Integrate device into SIMATIC PDM with Device Install.

If you use PDM version 6.0, refer to PDM manual, section 13 - Integrating devices.

For more data, refer to "readme.txt". You can find this file in the Installation Kit.

9.8.2 Operation



INFORMATION!

For more data, refer to HART® menu tree for PDM on page 138.

There can be differences between the names of menus in the SIMATIC PDM software tool and menus shown on the device display screen. Refer to the online help in SIMATIC PDM to find the function number of each menu item. This function number agrees with the function number in the device menus.

Use the same procedure for the protection of parameters in the supervisor menu.

9.9 HART® menu tree for AMS

Abbreviations of the following tables:

- ^{Opt} Optional, depending on device version and configuration
- Rd Read only

9.9.1 Overview AMS menu tree (positions in menu tree)

Configure / Setup	Quick Setup	General
		Security
		Units
		Application
	Full Setup	Process
		Output
		Display
		Device
		Hart
	Service ^{Opt}	Calibration
Information		
Device Diagnostics	Device Status	
	Actual Values	
	Simulation	
	Test/Reset	
	Information	
Process Variables	Measured Values	
	Inputs/Outputs	

9.9.2 AMS menu tree (details for settings)

Configure / Setup

Quick Setup	General	Language / Tag / Long Tag	
	Security	Login / Change Password / Reset Passwords / Lock Status Rd / Lock / Unlock Device / Write Protect Rd / (De)activate Write Protection / Unlock Extended Range	
	Units	Unit Length / Unit Volume / Unit Mass	
	Application Assistant	Standard Setup / Record Empty Spectrum	
Full Setup	Process	Install. Parameters	Tank Type / Tank Height / Blocking Distance / Time Constant / Antenna Type / Antenna Extension / Distance Piece / Reference Offset / Tank Bottom Offset
		Process	Tracking Velocity / Epsilon R Product / Epsilon R Gas / Measuring Mode / Overfill Detection / Overfill Threshold ^{Opt} / Mult. Refl. Enable / Empty Spectrum Enable / Min. Peak Required / Min Plausibility Window
		Conversion	Select Conversion / Entry Count Rd / Conversion Table
Full Setup	Output	General	Type IO channel A Rd / Type IO Channel B Rd
		Current Output 1	Current Out 1 Variable / 0% Range / 100% Range / Current Out Range / Error Function / Low Error Current / High Error Current / D/A Trim PV ^{Opt}
Full Setup	Display	General	Language / Backlight
		1st Measurement Page	Function / 1st Value Variable / Format 1st Value / 2nd Value Variable ^{Opt} / Format 2nd Value ^{Opt} / 3rd Value Variable ^{Opt} / Format 3rd Value ^{Opt} / 0% Range ^{Opt} / 100% Range ^{Opt}
		2nd Measurement Page	Function / 1st Value Variable / Format 1st Value / 2nd Value Variable ^{Opt} / Format 2nd Value ^{Opt} / 3rd Value Variable ^{Opt} / Format 3rd Value ^{Opt} / 0% Range ^{Opt} / 100% Range ^{Opt}

Full Setup	Device	Information	Tag Rd / Long Tag Rd / Serial Number Rd / Manufacturer Rd / Device Name Rd / V Number Rd / Electronic Revision Rd / Field Device Revision Rd / Software Revision Rd / Hardware Revision Rd / Electronics Serial No. Rd / Production Date Rd
		Security	Login / Change Password / Reset Passwords / Lock Status Rd / Lock / Unlock Device / Write Protect Rd / (De)activate Write Protection / Unlock Extended Range
		Units	Unit Length / Unit Volume / Unit Mass
		Log	Operating Time Rd / Reset Log-Messages
		Factory Default	Reset To Fact. Default
Full Setup	HART	Identification & Info	Loop current Mode / Online Mode / Poll Address / Tag / Long Tag / Manufacturer Rd / Model Rd / Device Id Rd / Universal Rev Rd / Field Device Rev Rd / DD-Version Rd / Descriptor / Message / Date / Final assembly number / Configuration change count Rd / Software Rev Rd / Hardware rev Rd / Write Protect Rd / Number of request preambles Rd / Number of response preambles Rd
Service	Calibration	Calibration	Current Output 1
		Sensor	Manual Correction Offset / Manual Correction Factor / Correction Offset Rd / Correction Factor Rd / Correction Offset Extended ^{Rd, Opt} / Correction Factor Extended ^{Rd, Opt}

Device Diagnostics

Device Status	Condensed Status (NE 107)	Condensed Status (NE 107) Rd / Device Simulation Active Rd
	Standard	Device Status Rd / Ext. Device Status Rd / Write Protect Rd / Device Diagnostic Status 0 Rd / Device Diagnostic Status 1 Rd / AO Saturated Rd / AO Fixed Rd
	Additional	Device Status Simulation Rd / Failure (F) Rd / Function Check (C) Rd / Out of Specification (S) Rd / Maintenance Required (M) Rd / Electronics Information Rd / Sensor Information Rd
	Cluster Check	Cluster Number Rd / Failed Cluster Check Rd
Actual Values	Operating Time Rd / Sensor Value Rd / Media Level Rd / Distance Rd / Reflection Rd / Level Linearization ^{Rd, Opt} / Volume ^{Rd, Opt} / Mass ^{Rd, Opt} / Distance Linearization ^{Rd, Opt} / Ullage ^{Rd, Opt} / Ullage Mass ^{Rd, Opt} / Sensor Temp Rd / Converter Temp Rd	
Simulation	Process Variables	Simulation Values
	Device Status	Enable/Disable Status Simulation / Status Simulation ^{Opt}
	I/O	Loop Test
Test / Reset	Device Reset / Reset Configuration Changed Flag	
Information	Tag Rd / Long Tag Rd / Serial Number Rd / Manufacturer Rd / Device Name Rd / V Number Rd / Electronic Revision Rd / Field Device Revision Rd / Software Revision Rd / Hardware Revision Rd / Electronics Serial No. Rd / Production Date Rd / Calibration Date Rd / Operating Time Rd	

Process variables

Measured Value	Sensor Value Rd / Media Level Rd / Distance Rd / Reflection Rd / Level Linearization ^{Opt, Rd} / Volume ^{Opt, Rd} / Mass ^{Opt, Rd} / Distance Linearization ^{Opt, Rd} / Ullage ^{Opt, Rd} / Ullage Mass ^{Opt, Rd}
Inputs / Out	PV Rd / PV % Range Rd / PV output current Rd / SV Rd / TV Rd / QV Rd

9.10 HART® menu tree for PDM

Abbreviations of the following tables:

- ^{Opt} Optional, depending on device version and configuration
- Rd Read only
- ^{Cust} Custody lock protection
- ^{Loc} Local PDM, affects only PDM views

9.10.1 Overview PDM menu tree (positions in menu tree)

Overview: Device Menu

Download To Device...		
Upload To PG/PC...		
Quick Setup	General	
	Security	
	Units	
	Application Assistant	
Full Setup	Process	Install. Parameters
		Process
		Conversion
	Output	General
		Current Output 1
	Display	General
		1st Measurement Page
		2nd Measurement Page
	Device	Information
		Security
		Units
		Log
		Factory Default
HART	Identification & Info	
Service	Calibration	Calibration
		Sensor

Overview: View Menu

Measured Value
Input / Outputs

Overview: Diagnosis

Device Status	Condensed Status (NE 107)
	Standard
	Additional
	Cluster Check
Actual Values	
Simulation	Process Variables
	Device Status
	I/O
Test / Reset	
Information	

9.10.2 PDM menu tree (details for settings)

Device Menu

Download To Device...

Upload To PG/PC...

Quick Setup

General	Language / Tag / Long Tag
Security	Login / Change Password / Reset Passwords / Lock Status Rd / Lock/Unlock Device / Write Protect Rd / (De)activate Write Protection / Unlock Extended Range
Units	Unit Length / Unit Volume / Unit Mass
Application Assistant	Standard Setup / Record Empty Spectrum

Full Setup

Process	Install. Parameters	Tank Type / Tank Height / Blocking Distance / Time Constant / Antenna Type / Antenna Extension / Distance Piece / Reference Offset / Tank Bottom Offset
	Process	Tracking Velocity / Epsilon R Product / Epsilon R Gas / Measuring Mode / Overfill Detection / Overfill Threshold ^{Opt} / Mult. Refl. Enable / Empty Spectrum Enable / Min. Peak Required / Min Plausibility Window
	Conversion	Select Conversion / Entry Count Rd / Conversion Table
Output	General	Type IO channel A Rd / Type IO Channel B Rd
	Current Output 1	Current Out 1 Variable / 0% Range / 100% Range / Current Out Range / Error Function / Low Error Current / High Error Current / D/A Trim PV ^{Opt}
Display	General	Language / Backlight
	1st Measurement Page	Function / 1st Value Variable / Format 1st Value / 2nd Value Variable ^{Opt} / Format 2nd Value ^{Opt} / 3rd Value Variable ^{Opt} / Format 3rd Value ^{Opt} / 0% Range ^{Opt} / 100% Range ^{Opt}
	2nd Measurement Page	Function / 1st Value Variable / Format 1st Value / 2nd Value Variable ^{Opt} / Format 2nd Value ^{Opt} / 3rd Value Variable ^{Opt} / Format 3rd Value ^{Opt} / 0% Range ^{Opt} / 100% Range ^{Opt}

Device	Information	Tag Rd / Long Tag Rd / Serial Number Rd / Manufacturer Rd / Device Name Rd / V Number Rd / Electronic Revision Rd / Field Device Revision Rd / Software Revision Rd / Hardware Revision Rd / Electronics Serial No. Rd / Production Date Rd
	Security	Login / Change Password / Reset Passwords / Lock Status Rd / Lock/Unlock Device / Write Protect Rd / (De)activate Write Protection / Unlock Extended Range
	Units	Unit Length / Unit Volume / Unit Mass
	Log	Operating Time Rd / Reset Log-Messages
	Factory Default	Reset To Fact. Default
HART	Identification & Info	Loop current Mode / Online Mode / Poll Address / Tag / Long Tag / Manufacturer Rd / Model Rd / Device Id Rd / Universal Rev Rd / Field Device Rev Rd / DD-Version Rd / Descriptor / Message / Date / Final assembly number / Configuration change count Rd / Software Rev Rd / Hardware rev Rd / Write Protect Rd / Number of request preambles Rd / Number of response preambles Rd
HART	Identification & Info	Loop current Mode / Online Mode Poll Address / Tag / Long Tag / Manufacturer Rd / Model Rd / Device Id Rd / Universal Rev Rd / Field Device Rev Rd / DD-Version Rd / Descriptor / Message / Date / Final assembly number / Configuration change count Rd / Software Rev Rd / Hardware rev Rd / Write Protect Rd / Number of request preambles Rd / Number of response preambles Rd

Service

Calibration	Calibration	Current Output 1
	Sensor	Manual Correction Offset / Manual Correction Factor / Correction Offset Rd / Correction Factor Rd / Correction Offset Extended ^{Rd, Opt} / Correction Factor Extended ^{Rd, Opt}

View Menu

Measurement Value

Sensor Value Rd / Media Level Rd / Distance Rd / Reflection Rd / Level Linearization ^{Opt, Rd} / Volume ^{Opt, Rd} / Mass ^{Opt, Rd} / Distance Linearization ^{Opt, Rd} / Ullage ^{Opt, Rd} / Ullage Mass ^{Opt, Rd}
--

Input / Outputs

PV Rd / PV % Range Rd / PV output current Rd / SV Rd / TV Rd / QV Rd
--

Diagnosis

Device Status

Condensed Status (NE 107)	Condensed Status (NE 107) Rd / Device Simulation Active Rd
Standard	Device Status Rd / Ext. Device Status Rd / Write Protect Rd / Device Diagnostic Status 0 Rd / Device Diagnostic Status 1 Rd / AO Saturated Rd / AO Fixed Rd
Additional	Device Status Simulation Rd / Failure (F) Rd / Function Check (C) Rd / Out of Specification (S) Rd / Maintenance Required (M) Rd / Electronics Information Rd / Sensor Information Rd
Cluster Check	Cluster Number Rd / Failed Cluster Check Rd

Actual Values

Operating Time Rd / Sensor Value Rd / Media Level Rd / Distance Rd / Reflection Rd / Level Linearization ^{Rd, Opt} / Volume ^{Rd, Opt} / Mass ^{Rd, Opt} / Distance Linearization ^{Rd, Opt} / Ullage Volume ^{Rd, Opt} / Ullage Mass ^{Rd, Opt} / Sensor Temp Rd / Converter Temp Rd

Simulation

Process Variables	Simulation Values
Device Status	Enable/Disable Status Simulation / Status Simulation ^{Opt}
I/O	Loop Test

Test / Reset

Device Reset / Reset Configuration Changed Flag
Information
Tag Rd / Long Tag Rd / Serial Number Rd / Manufacturer Rd / Device Name Rd / V Number Rd / Electronic Revision Rd / Field Device Revision Rd / Software Revision Rd / Hardware Revision Rd / Electronics Serial No. Rd / Production Date Rd / Calibration Date Rd / Operating Time Rd

10.1 Order code

Make a selection from each column to get the full order code.

RA	4	REFLEX RA Series FMCW Radar - 80 GHz radar (FMCW) level transmitter for liquids with hygienic requirements (up to 40 barg (580 psig) and 150°C (302°F))		
		Ex approvals		
		0	Without	
		1	ATEX II 1/2 G Ex ia IIC T6...T3 Ga/Gb + II 1/2 D Ex ia IIIC T85°C...T150°C Da/Db	
		2	ATEX II 1/2 G Ex db ia IIC T6...T3 Ga/Gb + II 1/2 D Ex ia tb IIIC T85°C...T150°C Da/Db	
		A	cQPSus IS CL I/II/III DIV 1 GP A-G + CL I Z0 AEx ia/Ex ia IIC T6...T3 Ga + Z20 AEx ia/Ex ia IIIC T85°C...T150°C Da ①	
		B	cQPSus XP-IS/DIP CL I DIV 1 GP A-G + CL I Z1 AEx db ia/Ex db ia IIC T6...T3 Gb + Z21 AEx ia tb/Ex ia tb IIIC T85°C...T150°C Db ②	
		C	cQPSus NI CL I/II/III DIV 2 GP ABCDFG ①	
		Industry / Safety		
		A	Food contact (FDA / EC 1935/2004 + EC 2023/2006 and EU 10/2011)	
		B	Food contact (FDA / EC 1935/2004 + EC 2023/2006 and EU 10/2011) + 3-A® ①	
		C	Food contact (FDA / EC 1935/2004 + EC 2023/2006 and EU 10/2011) + EHEDG ③	
		Converter version (Housing material / IP class)		
		2	C / Compact version (aluminium housing – IP66/68 0.1 barg)	
		3	C / Compact version (stainless steel housing – IP66/68 0.1 barg) ④	
		Outputs		
		1	2-wire / 4...20mA passive HART®	
		7	PROFIBUS PA (2 wire) ①	
RA	4	Order code (complete this code on the pages that follow)		

							Cable entry / cable gland
						1	M20×1.5 / without
						2	M20×1.5 / 1 × plastic + plug
						3	M20×1.5 / 1 × nickel-plated brass + plug
						4	M20×1.5 / 1 × stainless steel + plug
						5	M20×1.5 / 1 × M12 (4-pin connector) + plug
						6	M20×1.5 / 2 × plastic
						7	M20×1.5 / 2 × nickel-plated brass
						8	M20×1.5 / 2 × stainless steel
						A	M20×1.5 / 2 × M12 (4-pin connector)
						C	½ NPT nickel-plated brass adaptor / without
						D	½ NPT nickel-plated brass adaptor / 1 × nickel-plated brass + plug
						E	½ NPT stainless steel adaptor / 1 × stainless steel + plug
						F	½ NPT nickel-plated brass adaptor / 2 × nickel-plated brass
						G	½ NPT stainless steel adaptor / 2 × stainless steel
							Display
						0	Without (no display, cover without window)
						4	Plug-in display (cover with window)
							Display – Documentation language
						1	English
						2	German
						3	French
						4	Italian
						5	Spanish
						6	Portuguese
						7	Japanese
						8	Chinese (simplified)
						A	Russian
						B	Czech
						C	Turkish
						D	Polish
							Process conditions (Pressure, temperature, material and remarks) / Process seal
						1	-1...10 barg (-14.5...145 psig) / -40°C...+150°C (-40°F...+302°F) / PEEK ⑤
						2	-1...25 barg (-14.5...362 psig) / -40°C...+150°C (-40°F...+302°F) / PEEK ⑥
RA	4			0			Order code (complete this code on the pages that follow)

														Antennas (antenna type, material, radio approval)			
														2	Lens, DN25 (1") / PEEK / TLPR ⑦		
														3	Lens, DN40 (1½") / PEEK / LPR ⑧		
														0	Process connection: Size / Pressure class / Type		
														Hygienic (surface roughness, Ra <0.8 µm / 32 µin – AARH)			
														G	F	S	1½" Tri-Clamp® ISO 2852 / 3-A®
														H	F	S	2" Tri-Clamp® ISO 2852 / 3-A®
														G	F	T	DN40 DIN 11851
														H	F	T	DN50 DIN 11851
														H	F	U	DN51 SMS 1145 ⑨
														H	D	V	DN50 VARIVENT® Type N / EHEDG
														H	F	W	DN50 NEUMO BioControl® with EPDM gasket
														G	F	X	DN40 DIN 11864-1 Form A ⑨
														H	F	X	DN50 DIN 11864-1 Form A ⑨
														Calibration certificate			
														0	Without: Accuracy ±2 mm (±0.08")		
														1	Calibration certificate ±2 mm (±0.08") up to 10 m (32.81 ft), 2 points		
														2	Calibration certificate ±2 mm (±0.08") up to 10 m (32.81 ft), 5 points		
														3	Calibration certificate ±2 mm (±0.08") up to 10 m (32.81 ft), 5 points specified by the customer min. ≥ 1000 mm (39.4")		
														Options			
														0	Without		
														5	Electropolished wetted parts		
														Accessories / Tag plate			
														0	Without		
														1	Weather protection		
														3	Stainless steel Tag plate (18 characters max.)		
														6	Weather protection + Stainless steel Tag plate (18 characters max.)		
RA	4												0	Order code			

① Pending

② Pending. DIP = Dust Ignition Proof.

③ For Tri-Clamp®, DIN 11851, VARIVENT® and DIN 11864-1 Form A connections

④ This housing option has Ex ia approvals. The Ex d approval for this option is pending.

⑤ For DN25 (1") Lens antenna with the adaptor for DN50 VARIVENT® Type N

⑥ For all Lens antennas and process connections, but do not use with the adaptor for DN50 VARIVENT® Type N

⑦ Not available with the DN50 NEUMO BioControl® process connection. LPR = You can install the antenna in a closed tank or outdoors, but the antenna must point down. Do install LPR devices near sensitive installations (e.g. a radio astronomy station). TLPR = You must install the antenna in a closed tank.

⑧ Only available with the 2" Tri-Clamp® and DN50 NEUMO BioControl® process connections. LPR = You can install the antenna in a closed tank or outdoors, but the antenna must point down. Do install LPR devices near sensitive installations (e.g. a radio astronomy station). TLPR = You must install the antenna in a closed tank.

⑨ The process connection includes the ring nut

10.2 Spare parts

We supply spare parts for this device. When you send an order for a mechanical spare part, use the reference numbers in the table that follows. When you send an order for an electronic spare part, refer to *Order code* on page 143 and use the RA order code.

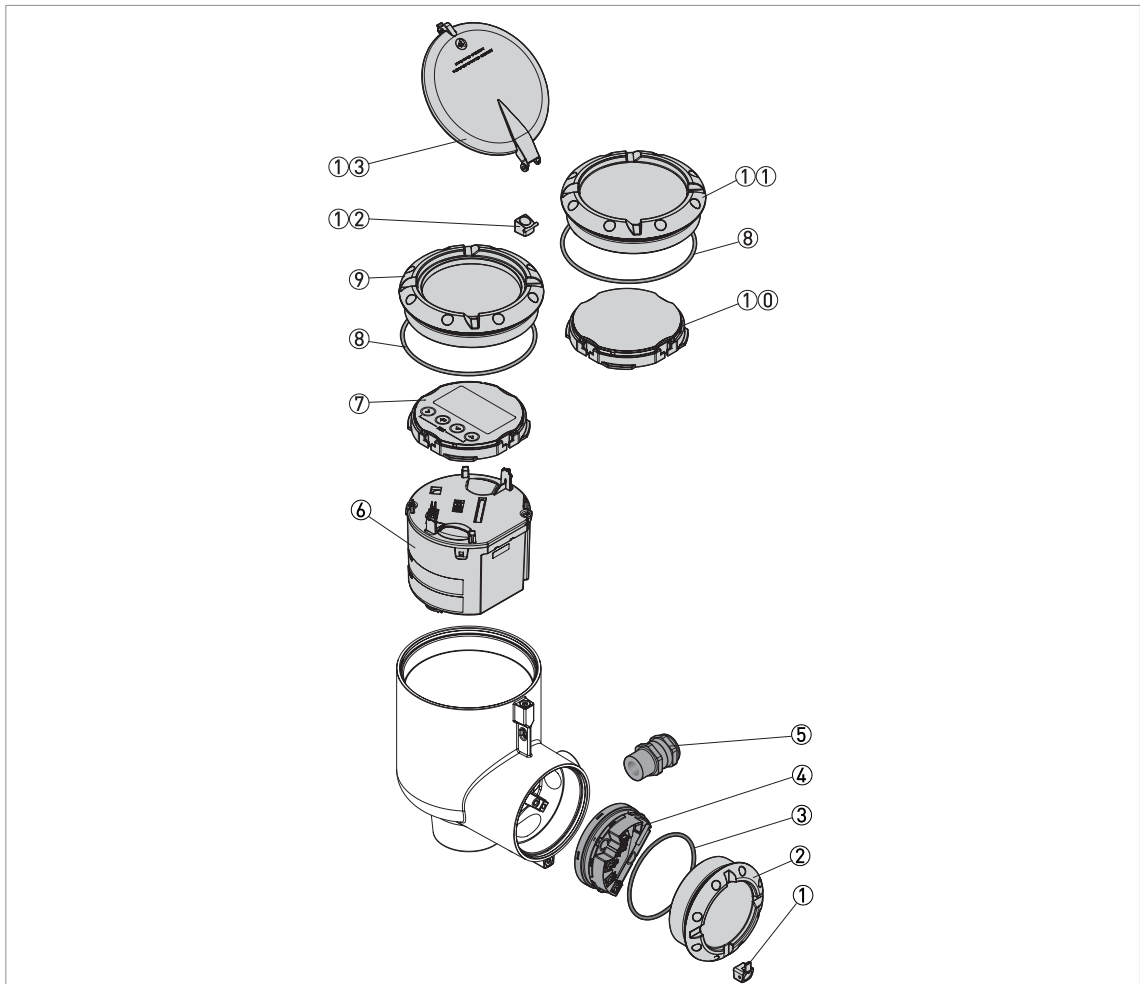

Figure 10-1: Other spare parts

- ① Cover stop
- ② Terminal compartment cover
- ③ Gasket for terminal compartment cover ②
- ④ Terminal cartridge
- ⑤ Cable gland
- ⑥ Signal converter
- ⑦ Display module
- ⑧ Gasket for display cover ⑨ or blind cover ⑩①
- ⑨ Display cover
- ⑩ Dummy module
- ⑩① Blind cover
- ⑩② Hinge
- ⑩③ Plastic sun cover for display cover ⑨

Description	Quantity	Part reference
-------------	----------	----------------

Housing

Aluminium blind cover (11) + gasket (8) + cover stop (1)	1	XFDX010102
Stainless steel blind cover (11) + gasket (8) + cover stop (1)	1	XFDX010202
Aluminium display cover (9) + gasket (8)	1	XFDX010302
Stainless steel display cover (9) + gasket (8)	1	XFDX010402
Aluminium terminal compartment cover (2) + gasket (3) + cover stop (1)	1	XFDX010502
Stainless steel terminal compartment cover (2) + gasket (3) + cover stop (1)	1	XFDX010602
Plastic sun cover for display cover (13) + hinge (12)	2	XFDX010702
O-ring gaskets set (3) + (8)	5	XFDX010800

Display

Display module (7)	1	XFDX020102
Display module (7) + aluminium display cover (9) + gasket (8)	1	XFDX020202
Display module (7) + stainless steel display cover (9) + gasket (8)	1	XFDX020302
Dummy module (10)	1	XFDX020402

Back end electronic board

Signal converter, HART® 2-wire (6)	1	XFDA030102
---	---	------------

Terminal cartridge

Terminal cartridge Non-Ex (GP) or Ex i (IS) (4)	1	XFDX040100
Terminal cartridge Ex d (XP) (4)	1	XFDX040200

Cable gland / Cable entry

Cable gland / M20×1.5 Plastic black non-Ex (GP) (5)	10	XFDX050100
Cable gland / M20×1.5 plastic blue Ex i (IS) (5)	10	XFDX050200
Cable gland / M20×1.5 nickel-plated brass Ex d (XP) (5)	5	XFDX050300
Cable gland / M20×1.5 stainless steel Ex d (XP) (5)	2	XFDX050400
Cable gland / M20×1.5 nickel-plated brass non-Ex (GP) / Ex i (IS) (5)	5	XFDX050500
Cable gland / M20×1.5 stainless steel non-Ex (GP) / Ex i (IS) (5)	2	XFDX050600
Connector M12×1 (4-pin connector) (5)	5	XFDX050700
Cable entry / ½ NPT nickel-plated brass Ex d (5)	5	XFDX050800
Cable entry / ½ NPT nickel-plated brass cQPSus (5)	5	XFDX050900
Cable entry / ½ NPT stainless steel non-Ex (GP) / Ex i (5)	2	XFDX051000
Cable entry / ½ NPT stainless steel Ex d (5)	2	XFDX051100
Cable entry / ½ NPT stainless steel cQPSus (5)	2	XFDX051200

10.3 Accessories

We supply accessories for this device. When you send an order for accessories, please give the reference numbers that follow:

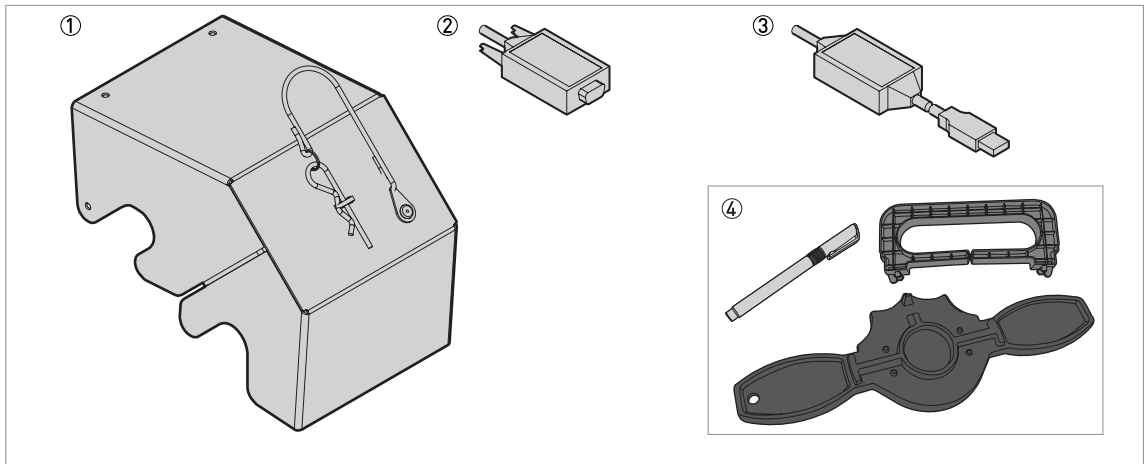

Figure 10-2: Accessories

- ① Weather protection
- ② Viator RS232 / HART converter
- ③ Viator USB / HART converter
- ④ Display extractor, magnet and cover wrench

Item	Description	Quantity	Part reference
①	Weather protection	1	XFDX060100
②	Viator RS232 / HART converter	1	XFDX060200
③	Viator USB / HART converter	1	XFDX060300
④	Display extractor, magnet and cover wrench	5	XFDX060400
—	USB / 24 V DC power supply	1	XFDX060500

10.4 Glossary

D

Dead zone	Non-measurement zone.
Dielectric constant	An electrical property of the product to be measured used in radar measurement. Also known as ϵ_r , DK and relative permittivity. Defines the strength of the wave reflected back to the device's signal converter.
Distance	The distance from the face of flange to the level (1 product) or the surface of the top product (2 or more products). See the diagrams at the end of this section.
DTM	Device Type Manager. A driver for use in the PACTware™ program. All data and functions of the device are included in it.

E

Electromagnetic compatibility (EMC)	Defines how much a device influences or is influenced by other devices that generate electromagnetic fields during operation. Refer to European standard EN 61326-1 for further details.
--	--

F

FMCW	Frequency-modulated continuous-wave radar technology. The signal is continuously present, but the frequency is modulated, usually in successive linear ramps over time (frequency sweeps).
-------------	--

H

Hazardous area	An area with a potentially explosive atmosphere. Trained personnel can install and use a device in this area. The device must be ordered with the appropriate options. The device requires approvals (ATEX, IECEx, cQPSus, NEPSI etc.) related to site specifications. You can find more data about hazardous areas in the Ex Manuals and Ex Certificates of Compliance.
-----------------------	--

I

Interference signals	False radar reflections usually caused by equipment in the tank.
-----------------------------	--

L

Lens antenna	An antenna with a small convex or concave surface that is made of a material that agrees with FDA regulations. It can be supplied with common hygienic process connection options (Tri-Clamp®, BioControl®, SMS, ...).
Level	Height from the bottom of the tank (user-defined) to the surface of the top product (Tank height – distance). See the diagrams at the end of this section.

M

Mass	Total mass of tank contents.
-------------	------------------------------

P**PACTware™**

Software that operates and configures field devices from a remote workstation. It is not necessary to use fieldbus software or programs developed by the manufacturer.

R**Radar reflection**

Signal reflected from the surface of the tank contents.

S**Signal converter**

A set of electronic components in the device that send the measurement signal through some signal filters. They identify and measure the level of the tank contents.

T**TBF**

Tank Bottom Following (TBF) mode is an alternative measurement mode. It allows the device to measure tank contents with very low dielectric constants. TBF mode uses the reflection of the tank bottom to indirectly measure the level of the tank contents.

U**Ullage volume**

Unfilled volume. See the diagrams at the end of this section.

V**Volume**

Total volume of tank contents.

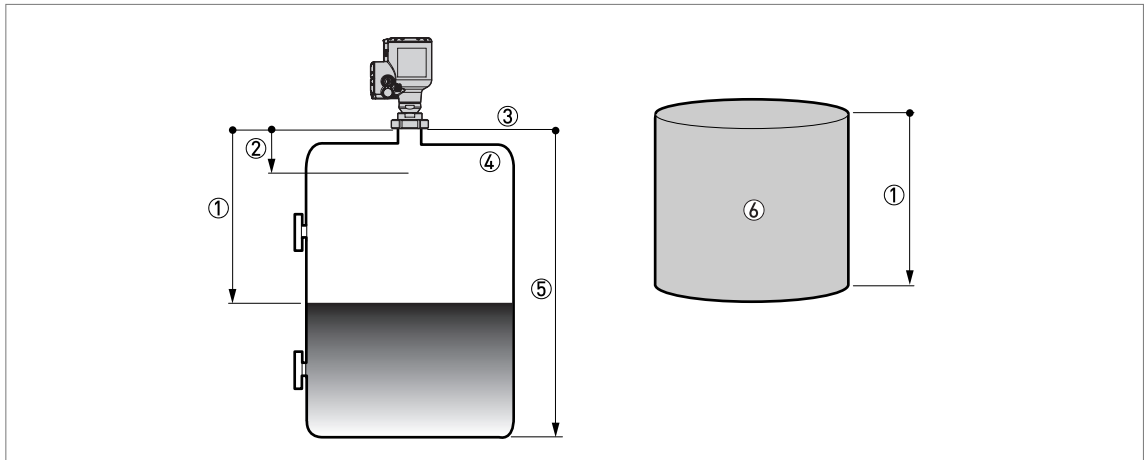

Figure 10-3: Measurement definitions: distance

- ① Distance
- ② Blocking distance
- ③ Flange facing
- ④ Gas (Air)
- ⑤ Tank height
- ⑥ Ullage volume or mass

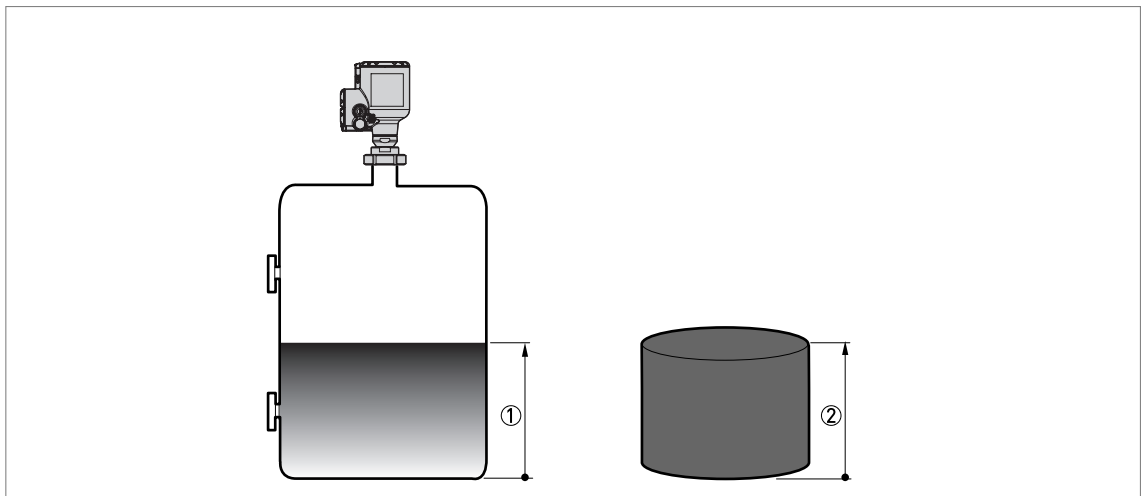

Figure 10-4: Measurement definitions: level

- ① Level
- ② Volume or mass

Hycontrol Ltd
Larchwood House
Orchard Street
Redditch
Worcestershire B98 7DP
United Kingdom
Tel: +44 (0) 1527 406800
Fax: +44 (0) 1527 406810
Email: sales@hycontrol.com
Web: www.hycontrol.com
Company registered in England No: 1755684