

Flow Measurement for Dry Bulk Solids

PROCESS MONITORING SYSTEMS FOR SOLIDS

Product Information



FEATURES:

- Most non-metallic solids can be measured
- Can be installed on round pipes or ducts
- No real upper limit of mass flow
- Dust tight
- No flow restrictions to the process flow (wear resistant ceramic liner)
- The mass flow measurement is independent of flow characteristics
- Maximum temperature: 120 °C
- Can be installed at an angle
- Small installation height, max. 310 mm
- No moving parts, hence no maintenance
- Easy to calibrate

TECHNOLOGY

USE

The MaxxFLOW HTC is specially developed for the flow measurement of dry bulk solids without any built-in in the flow. Due to its independence from any angle of the pipework and its low installation height, the MaxxFLOW HTC is especially suitable in situations in which it was previously only possible to use complicated or expensive mechanical solutions, e.g. impact plates or measuring chutes.

The installation of the MaxxFLOW HTC takes place independently of the direction of the line (vertical/inclined), but always after mechanical conveyor elements, e.g. rotary feeder, screw conveyors, air slides or chain conveyors.

FUNCTION

After the conveyor, the material to be measured falls or slides through an inlet path and runs through the sensor. During the throughput, the MaxxFLOW HTC records the material density and speed. Since the material falls from a constant height after emerging from the conveyor element, the speed of the product stream is accelerated, but is constant at the installation position of the sensor. Because of a speed measurement which takes place in the sensor, every time an accurate measurement can be guaranteed even under changing process conditions.

The mass flow is determined as follows:

$$Q_{(kg/s)} = K_{(kg/m^3)} \times v_{(m/s)} \times A_{(m^2)}$$

Through the input coupling of a high-frequency, electromagnetic alternating field, a homogenous measuring field is generated in the measuring tube. The measuring tube (interior tube of the sensor) consists of wear-resistant Al_2O_3 ceramics. Dry bulk solids inside the measuring field reduce the amplitude of the alternating field. This leads to a measuring signal, behaves with a system accuracy of 0.04 %, proportional to the concentration of the bulk solids in the sensor (kg/m^3).

If the material speed varies, for example due to a change in initial speed, then this can also be measured. This takes place through a runtime measurement with the help of two additional electrodes behind the interior ceramic tube.

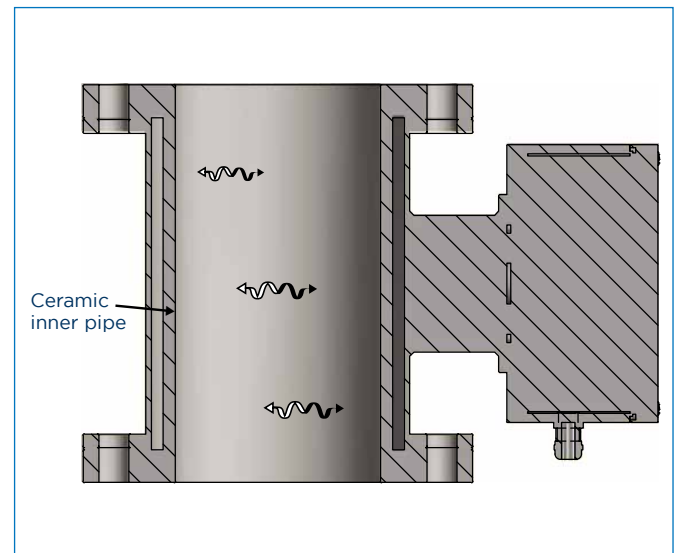

SYSTEM

A complete measuring point consists of these components:

- Sensor for installation in the conveyor line
- Evaluation Unit MSE 300

The sensor is available in sizes DN80 mm, DN100 mm, DN150 mm and DN200 mm.

With the design in DN80 mm, the connection flange could be freely selected.

The evaluation unit, in Field housing or DinRail version, is connected to the sensor using 4-wired, shielded cable.

The maximum distance between sensor and evaluation unit is 300 m.

FEATURES

- Installation free of obstacles in the cross-section, therefore no dead spots
- independent of the arrangement of the line (vertical or inclined)
- easy retrofitting
- dust proof
- non-contact measurement procedure (no mechanics)
- maximum material temperature 120 °C
- abrasion - resistant ceramic inner tube
- maintenance-free
- System accuracy: 0.04 %

CONFIGURATION

For the configuration of the sensors, the knowledge of the maximum volume flow is fundamentally important in order to configure the measuring point in such a way that the dry bulk solids can flow through the sensor unhindered and the product flow is not influenced.

The diagrams in figure 1 and 2 shows the maximum conveyable volume depending on material speed.

The sensor cross-section in all cases is filled to 50 %.

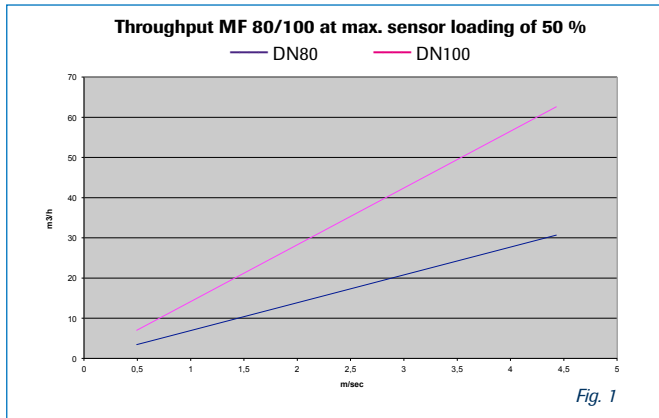

Which sensor type is used depends on the available installation height and the desired measuring range.

The measuring point itself has an installation height, depending on the diameter, from 292 mm (DN80) to 310 mm (DN200 mm).

The turndown, the ratio between the end of the measuring range and the beginning of the measuring range, is 1:5 for all MaxxFlow HTC sensors.

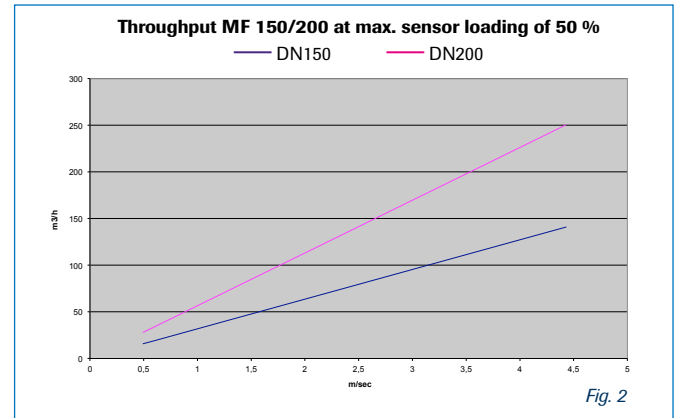

CALIBRATION

For the MaxxFlow HTC, there are different options for calibration, **EasyFull** and **EasyFlow** calibration.

- With the **EasyFull** calibration, the sensor is calibrated via a full calibration. For this purpose, the sensor is filled to 100 % and then the bulk density in kg/m³ deposited in the evaluation unit. Because to the material-independent speed measurement, the sensor is now able to calculate the throughput.
- The **EasyFlow** calibration also provides the ability to calibrate the sensor direct to the process conditions. For this type of calibration, references to different process conditions are made and compared to the sensor signal. EasyFlow calibration can achieve a measurement accuracy of < 2 %.

DIMENSIONS

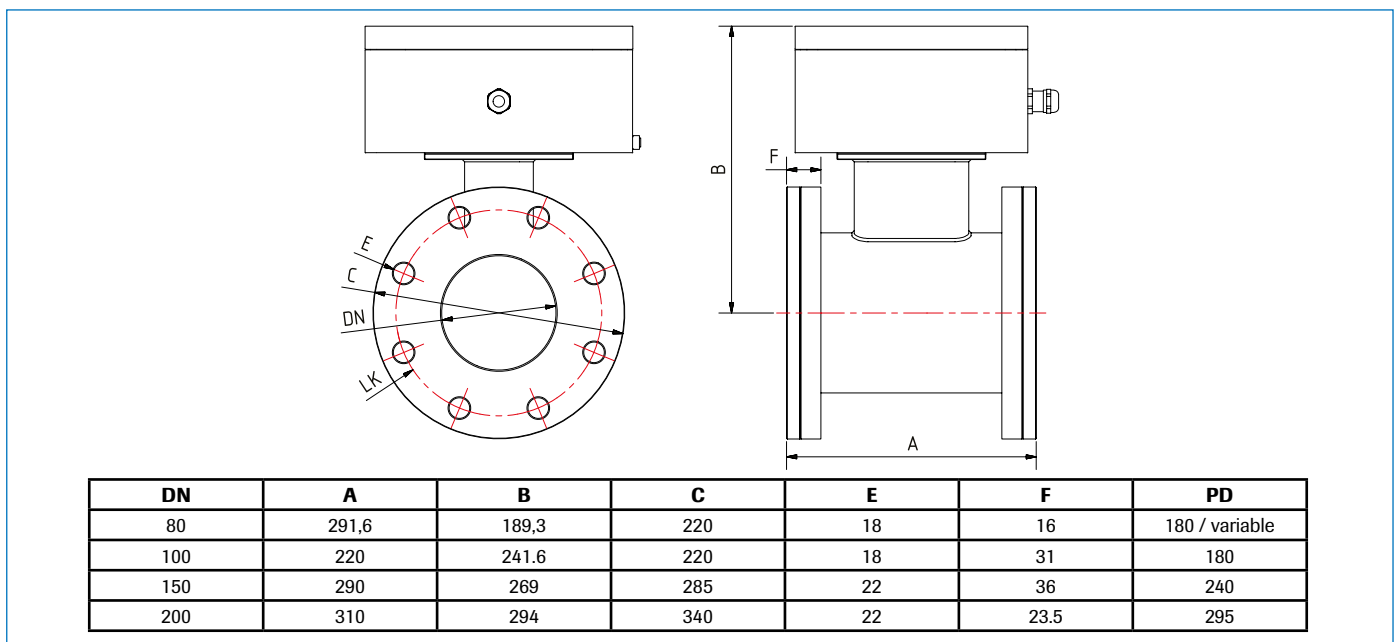

SPECIFICATIONS

TECHNICAL DATA

Sensor

| | |
|-----------------------|---|
| Housing material | Steel St 52, powder-coated (optional stainless steel 1.4571) NW 80/100/150/200 mm, Flange according EN 1092-1 / PN10 DN80: variable |
| Inner pipe | Al ₂ O ₃ -Ceramic |
| Protection category | IP65 |
| Operating temperature | Sensor pipe: - 20 ... + 120 °C Sensor electronic: 0 ... + 60 °C |
| Max. working pressure | 1 bar |
| Working frequency | 88 kHz |
| Transmitting power | Max. 2 mW |
| Weight | Depend on diameter |
| Accuracy | ± 1 ... 3 % (based on end of measuring range and calibrated material) |
| System accuracy | ± 0.04 % |

MSE 300-DR (DIN Rail)

| | |
|--|---|
| Power supply | 24 V DC ± 10 % |
| Power consumption | 20 W / 24 VA |
| Protection type | IP40 to EN 60 529 |
| Ambient operating temperature | -10 ... +45 °C |
| Dimensions | 23 x 90 x 118 mm (W x H x D) |
| Weight | Approx. 172 g |
| DIN rail fastening | DIN 60715 TH35 |
| Connection terminals cable cross-section | 0.2 - 2.5 mm ² [AWG 24-14] |
| Current output | 1 x 4 ... 20 mA (0 ... 20 mA), load < 500 Ω (Active) |
| Interface | ModBus RTU (RS 485) / USB |
| Pulse output | Open Collector - max. 30 V, 20 mA |
| Relay contact | Max. rated load: 250 V AC Max. peak current: 6 A Max. rated load 230 V AC: 250 VA Max. breaking capacity DC1: 3/110/220 V: 3/0.35/0.2 A Min. switching load: 500 mW (10 V / 5 mA) |
| Data backup | Flash Memory |

MSE 300-FH (Field Housing)

| | |
|--|---|
| Power supply | 110 / 230 V AC 50 Hz (optional 24 V DC) |
| Power consumption | 20 W / 24 VA |
| Protection type | IP65 to EN 60 52910.91 |
| Ambient operating temperature | -10 ... +45 °C |
| Dimensions | 258 x 237 x 174 mm (W x H x D) |
| Weight | Approx. 2.5 kg |
| Interface | RS 485 (ModBus RTU) / USB |
| Cable screw connectors | 3 x M20 (4.5 - 13 mm Ø) |
| Connection terminals cable cross-section | 0.2 - 2.5 mm ² [AWG 24-14] |
| Current output | 3 x 4 ... 20 mA (0 ... 20 mA), load < 500 Ω (Active) |
| Pulse output | Open Collector - max. 30 V, 20 mA |
| Relay contact | Max. rated load: 250 V AC Max. peak current: 6 A Max. rated load 230 V AC: 250 VA Max. breaking capacity DC1: 3/110/220 V: 3/0.35/0.2 A Min. switching load: 500 mW (10 V / 5 mA) |
| Data backup | Flash Memory |

